



# PACIFIC DISPLAY DEVICES

## LCD Component Data Sheet

**Model Number: 16230**

**16 Character by 2 Line  
Alphanumeric LCD Assembly  
With Embedded Controller**

### CONTENTS

1.	GENERAL INFORMATION	
1.1	Product Overview	2
1.2	Part Numbering System	2
1.3	Absolute Maximum Ratings	3
1.4	Circuit Block Diagram	3
1.5	Mechanical Characteristics	3
1.6	Input Signal Function	4
1.7	LCM Contrast Control and Bias	4
1.8	LCD Dimensions	5
2.	ELECTRICAL / OPTICAL CHARACTERISTICS	
2.1	DC Electrical Characteristics	6
2.2	AC Electrical Characteristics	6
2.3	Optical Characteristics	7
2.4	LED Backlight Characteristics	8
2.5	EL Panel Backlight Characteristics	8
3.	OPERATING PRINCIPALS AND METHODS	
3.1	LCD Controller Display and Control Functions	9
3.2	Display Data RAM Address Map	9
4.	RELIABILITY	10
5.	PRECAUTIONS FOR USING LCD MODULES	11

## 1. GENERAL INFORMATION

### 1.1 Product Overview

- 16 Character x 2 line Alphanumeric Dot Matrix LCD Module
- LCD Controller: Embedded ST7066U (or equivalent) alpha-numeric controller (ROM code 0A)
- Multiplexing driving: 1/16 duty, 1/5 bias
- Operating Mode: Super Twisted Nematic (STN) technology
- LCD Module Service Life: 100,000 hours minimum

### 1.2 Part Numbering System

16230	-xx	-SL	-F	-ST	-LED	-GY	-12
-------	-----	-----	----	-----	------	-----	-----

➤ **Custom Option Designator**

- (Can be left blank)

➤ **Operating Mode**

- (-GR) Green
- (-SL) Silver
- (-BN) Blue Negative

➤ **Rear Polarizer Options:**

- (-R) Reflective
- (-F) Transflective
- (-M) Transmissive

➤ **Operating Temperature**

- (-ST) Standard (0 to +50 °C)
- (-ET) Extended (-20 to +70 °C)

➤ **Backlight Options:**

- (-LED) LED Array Backlight
- (-ELED) LED Edge Lit Backlight
- (-ELP) EL Panel Backlight

➤ **Backlight Coloration Options:**

- (-GY) LED - Green/Yellow
- (-AM) LED - Amber
- (-RD) LED - Red
- (-BG) ELP – Blue Green

➤ **Viewing Angle**

- (-6) 6 o'clock
- (-12) 12 o'clock

### 1.3 Absolute Maximum Ratings

Parameter	Symbol	Min	Max	Unit
Supply voltage for logic	$V_{DD}$	-0.3	7.0	V
Supply voltage for LCD	$V_{DD} - V_0$	--	$V_{DD} + 0.3$	V
Input voltage	$V_I$	-0.3	$V_{DD} + 0.3$	V
Standard Operating temperature	TOP (-ST)	0	50	°C
Standard Storage temperature	TST (-ST)	-10	60	°C
Extended Operating temperature	TOP (-ET)	-20	70	°C
Extended Storage temperature	TST (-ET)	-30	80	°C
Soldering Temp	Tsolder	260		°C

### 1.4 Circuit Block Diagram

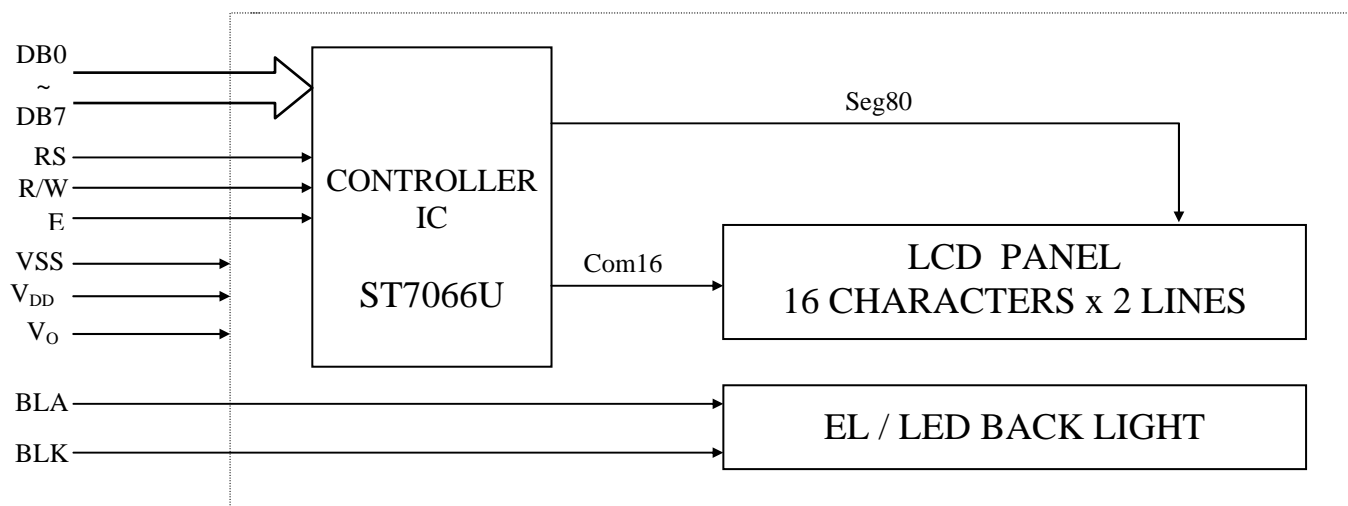

### 1.5 Mechanical Characteristics

Item	Contents	Unit
Module size (W×H×T)	122 x 44 x 14 Max (w/ LED Backlight) 122 x 44 x 10 Max (w/ ELP or No LED Backlight)	mm
Viewing area (W×H)	99 × 24	mm
Character matrix (W×H)	5 × 8	dots
Character size (W×H)	4.84 × 9.66	mm
Dot size (W×H)	0.92 × 1.10	mm
Dot pitch (W×H)	0.98 × 1.16	mm

**1.6 Input Signal Function**

Pin NO.	Symbol	Level	Description
1	VSS	0V	Ground
2	VDD	5.0V	Supply voltage for logic
3	VO	---	Input voltage for LCD
4	RS	H/L	H : Data signal, L : Instruction signal
5	R/W	H/L	H : Read mode, L : Write mode
6	E	H, H → L	Chip enable signal
7	DB0	H/L	Data bit 0
8	DB1	H/L	Data bit 1
9	DB2	H/L	Data bit 2
10	DB3	H/L	Data bit 3
11	DB4	H/L	Data bit 4
12	DB5	H/L	Data bit 5
13	DB6	H/L	Data bit 6
14	DB7	H/L	Data bit 7
15	BLA	4.2V	Back light anode
16	BLK	0V	Back light cathode

**1.7 LCM Contrast Control and Bias**

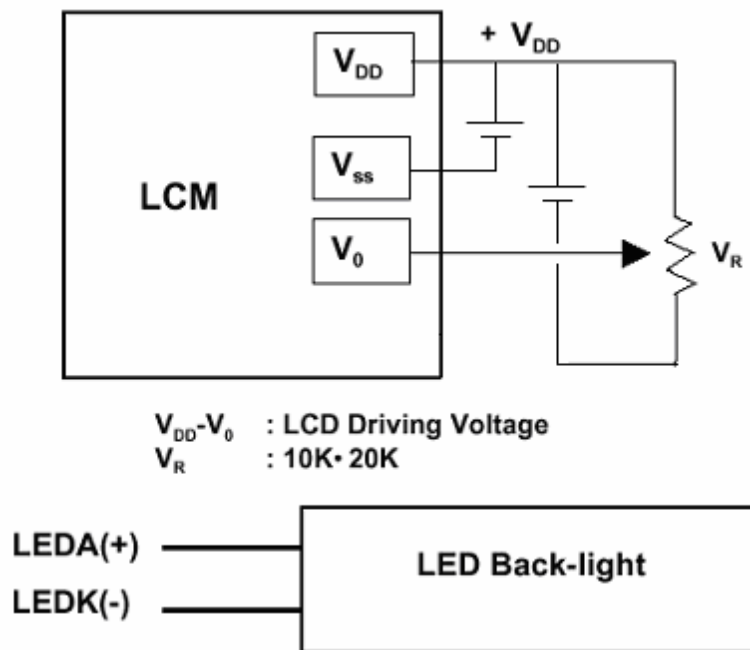

1.7 LCM Dimensions

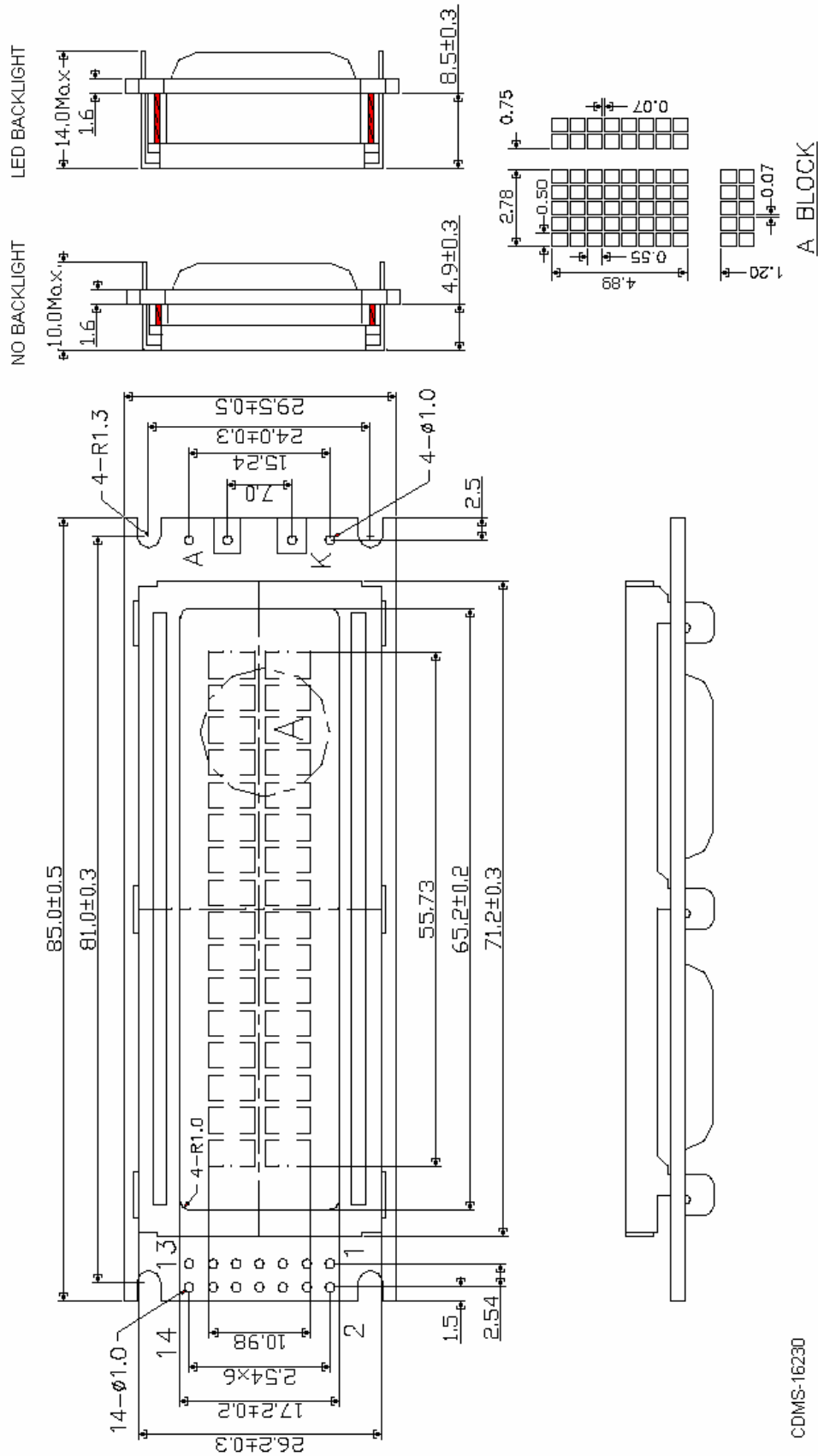

## 2. ELECTRICAL / OPTICAL CHARACTERISTICS

### 2.1 DC Electrical Characteristics (V<sub>DD</sub> = +5V±10% , V<sub>SS</sub> = 0V, Ta = 25°C )

Parameter	Symbol	Condition	Min	Typ	Max	Unit
Supply voltage for logic	V <sub>DD</sub>	---	4.5	5.0	5.5	V
Supply current for logic	I <sub>DD</sub>	---	---	1.38	3	mA
Operating voltage for LCD*	V <sub>DD</sub> -V <sub>O</sub>	0°C	4.7	5.0	5.3	V
		25°C	4.5	4.8	5.1	V
		50°C	4.4	4.7	5.0	V
Input voltage 'H' level	V <sub>IH</sub>	---	2.2	---	VDD	V
Input voltage 'L' level	V <sub>IL</sub>	---	-0.3	---	0.6	V

\*Note: -ET temp range will require up to 8V biasing and require a minimum external voltage supply of -3V @-20°C.

### 2.2 AC Electrical Characteristics

- Please review the hardware and software technical information in the ST7066U Data Sheet
- [http://www.pacificdisplay.com/ics\\_app%20notes/sitronix/ST7066U.pdf](http://www.pacificdisplay.com/ics_app%20notes/sitronix/ST7066U.pdf)

2.3 Optical Characteristics (V<sub>OP</sub> = 4.7V, T<sub>a</sub> = 25°C)

Item	Symbol	Condition	Min	Typ	Max	Unit	Remarks	Note
Response time	Tr	---	---	147	---	ms	---	1
	Tf	---	---	264	---	ms	---	1
Contrast ratio	Cr	---	---	5.6	---	---	---	2
Viewing angle range	θ	Cr ≥ 2	25	---	---	deg	∅ = 90°	3
			33	---	---	deg	∅ = 270°	3
			52	---	---	deg	∅ = 0°	3
			33	---	---	deg	∅ = 180°	3

Note1: Definition of response time.

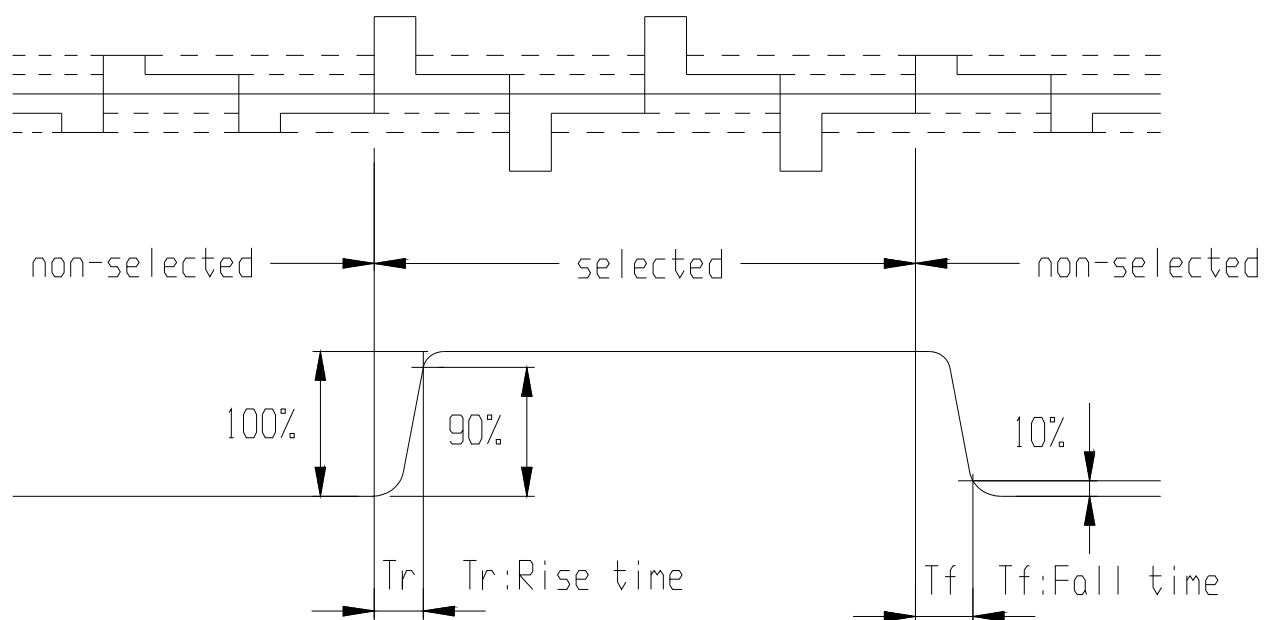

Note2: Definition of contrast ratio 'Cr' .

$$Cr = \frac{\text{Brightness of non-selected segment}(B2)}{\text{Brightness of selected segment}(B1)}$$

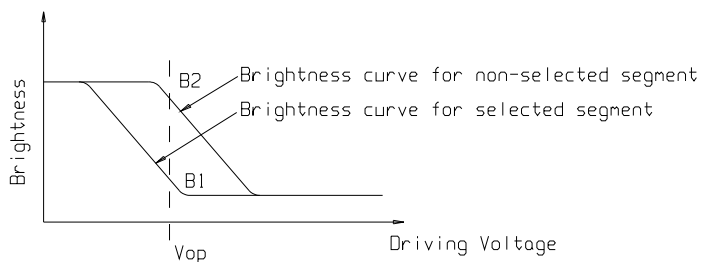

Note3: Definition of viewing angle range 'θ'.

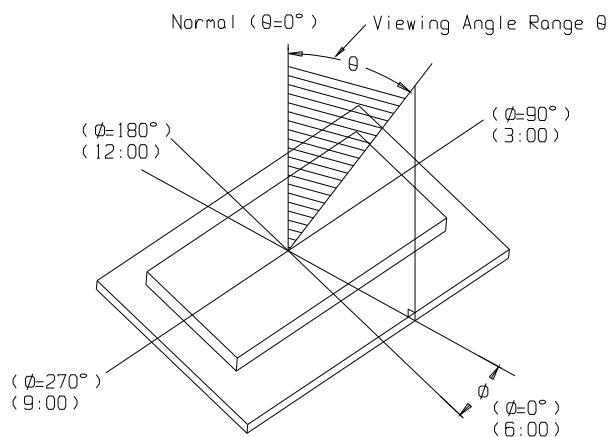

## 2.4 LED Backlight Characteristics

### ■ Yellow-Green LED Operating Characteristics (5V - Array Lit)

Item	Symbol	Conditions	Standard			Unit
			Min.	Typ.	Max.	
Forward Voltage	$V_f$	Ta= 25 °C	3.8	4.1	4.4	VDC
Forward Current	$I_F$	Ta= 25 °C	---	100	180	mA
Reverse Voltage	$V_R$	Ta= 25 °C	---	8	---	V

### ■ Life (Array or Edge Lit)

Item	Conditions	Standard		Unit
		Min.	Max.	
Life	Ta= 25 °C	100,000	---	hrs

## 2.5 EL Panel Backlight Characteristics

### ■ Blue-Green EL Panel Operating Characteristics:

Item	Conditions	Standard			Unit
		Min.	Typ.	Max.	
Current Consumption	100VAC RMS, 400Hz Ta: 25°C	---	2.4	3.6	mA
EL Drive Voltage	---	---	100	150	VAC RMS
EL Drive Frequency	---	---	400	1000	Hz
Operating Temperature	---	-35°C	---	+50°C	°C
Storage Temperature	---	-40°C	---	+60°C	°C
Luminance	100VAC RMS, 400Hz	40	50	---	cd/m <sup>2</sup>
Luminance Half-Life	Ta: 25°C	3500	---	---	Hrs

\*Note: half life is defined as Luminance being reduced by 50%



### 3. OPERATING PRINCIPALS AND METHODES

#### 3.1 LCD Controller Display and Control Functions

- Please review the hardware and software technical information in the ST7066U Data Sheet
- [http://www.pacificdisplay.com/ics\\_app%20notes/sitronix/ST7066U.pdf](http://www.pacificdisplay.com/ics_app%20notes/sitronix/ST7066U.pdf)

#### 3.2 Display Data RAM Address Map

- **LCD Character Location map**

Characters	1	2	3	4	5	6	7	8	9	10	11	12	13	14	15	16
First line	00H	01H	02H	03H	04H	05H	06H	07H	08H	09H	0AH	0BH	0CH	0DH	0EH	0FH
Second line	40H	41H	42H	43H	44H	45H	46H	47H	48H	49H	4AH	4BH	4CH	4DH	4EH	4FH

**4. RELIABILITY**

<b>Environmental Test</b>				
<b>No</b>	<b>Test Item</b>	<b>Content of Test</b>	<b>Test Condition</b>	<b>Applicable Standard</b>
1	High temperature storage	Endurance test applying the high storage temperature for a long time.	80 °C 200 hrs	-----
2	Low temperature storage	Endurance test applying the low storage temperature for a long time.	-30 °C 200 hrs	-----
3	High temperature operation	Endurance test applying the electric stress (Voltage & Current) and the thermal stress to the element for a long time.	70 °C 200 hrs	-----
4	Low temperature operation	Endurance test applying the electric stress under low temperature for a long time.	-20 °C 200 hrs	-----
5	High temperature / Humidity storage	Endurance test applying the high temperature and high humidity storage for a long time.	80 °C , 90 %RH 96 hrs	MIL-202E-103B JIS-C5023
6	High temperature / Humidity operation	Endurance test applying the electric stress (Voltage & Current) and temperature / humidity stress to the element for a long time.	70 °C , 90 %RH 96 hrs	MIL-202E-103B JIS-C5023
7	Temperature cycle	Endurance test applying the low and high temperature cycle.  $\begin{array}{c} -20^{\circ}\text{C} \quad 25^{\circ}\text{C} \quad 70^{\circ}\text{C} \\ 30\text{min.} \quad \rightleftharpoons \quad 5\text{min.} \quad \rightleftharpoons \quad 30\text{min.} \\ \leftarrow \hspace{10em} \rightarrow \\ 1 \end{array}$	-20°C / 70°C 10 cycles	-----
<b>Mechanical Test</b>				
8	Vibration test	Endurance test applying the vibration during transportation and using.	10~22Hz → 1.5mmp-p 22~500Hz → 1.5G Total 0.5hrs	MIL-202E-201A JIS-C5025 JIS-C7022-A-10
9	Shock test	Constructional and mechanical endurance test applying the shock during transportation.	50G Half sign wave 11 msdc 3 times of each direction	MIL-202E-213B
10	Atmospheric pressure test	Endurance test applying the atmospheric pressure during transportation by air.	115 mbar 40 hrs	MIL-202E-105C
<b>Others</b>				
11	Static electricity test	Endurance test applying the electric stress to the terminal.	VS=800V , RS=1.5 kΩ CS=100 pF 1 time	MIL-883B-3015.1

\*\*\* Supply voltage for logic system = VDD. Supply voltage for LCD system = Operating voltage at 25°C

**LCD Panel Service Life****Definition of panel service life**

- 100,000 hours minimum at 25° C ±10%
- Contrast becomes 30% of initial value
- Current consumption becomes three times higher than initial value
- Remarkable alignment deterioration occurs in LCD cell layer
- Unusual operation occurs in display functions

## 5. PRECAUTIONS FOR USING LCD MODULES

### Installing LCD Modules

The hole in the printed circuit board is used to fix LCM as shown in the picture below. Attend to the following items when installing the LCM.

- 1) Cover the surface with a transparent protective plate to protect the polarizer and LC cell.

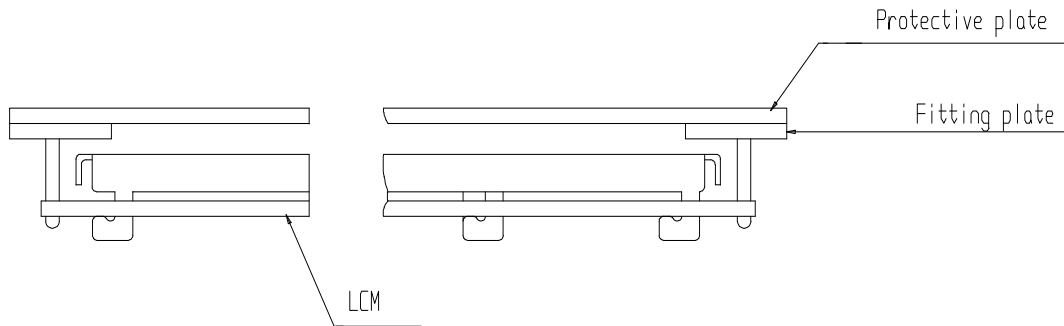

- 2) When assembling the LCM into other equipment, the spacer to the bit between the LCM and the fitting plate should have enough height to avoid causing stress to the module surface, refer to the individual specifications for measurements. The measurement tolerance should be  $\pm 0.1$  mm.

### Precaution for Handling LCD Modules

Since LCM has been assembled and adjusted with a high degree of precision, avoid applying excessive shocks to the module or making any alterations or modifications to it.

- 1) Cover the surface with a transparent protective plate to protect the polarizer and LC cell.
- 2) Do not alter, modify or change the shape of the tab on the metal frame.
- 3) Do not make extra holes on the printed circuit board, modify its shape or change the positions of components to be attached.
- 4) Do not damage or modify the pattern writing on the printed circuit board.
- 5) Absolutely do not modify the zebra rubber strip (conductive rubber) or heat seal connector.
- 6) Except for soldering the interface, do not make any alterations or modifications with a soldering iron.
- 7) Do not drop, bend or twist LCM.

### Electro-Static Discharge Control

Since this module uses a CMOS LSI, the same careful attention should be paid to electrostatic discharge as for an ordinary CMOS IC.

- 1) Make certain that you are grounded when handling LCM.
- 2) Before remove LCM from its packing case or incorporating it into a set, be sure the module and your body have the same electric potential.
- 3) When soldering the terminal of LCM, make certain the AC power source for the soldering iron does not leak.
- 4) When using an electric screwdriver to attach LCM, the screwdriver should be of ground potentiality to minimize as much as possible any transmission of electromagnetic waves produced sparks coming from the commutator of the motor.
- 5) As far as possible make the electric potential of your work clothes and that of the work bench the ground potential.
- 6) To reduce the generation of static electricity be careful that the air in the work is not too dried. A relative humidity of 50%-60% is recommended.

### Precaution for soldering to the LCM

- 1) Observe the following when soldering lead wire, connector cable and etc. to the LCM.
  - a) Soldering iron temperature :  $280^{\circ}\text{C} \pm 10^{\circ}\text{C}$ .
  - b) Soldering time : 3-4 sec.
- 2) Solder : eutectic solder.

- 3) If soldering flux is used, be sure to remove any remaining flux after finishing to soldering operation. (This does not apply in the case of a non-halogen type of flux.) It is recommended that you protect the LCD surface with a cover during soldering to prevent any damage due to flux spatters.
- 4) When soldering the electroluminescent panel and PC board, the panel and board should not be detached more than three times. This maximum number is determined by the temperature and time conditions mentioned above, though there may be some variance depending on the temperature of the soldering iron.
- 5) When remove the electroluminescent panel from the PC board, be sure the solder has completely melted, the soldered pad on the PC board could be damaged.

### Precautions for Operation

- 1) Viewing angle varies with the change of liquid crystal driving voltage (VO). Adjust VO to show the best contrast.
- 2) Driving the LCD in the voltage above the limit shortens its life.
- 3) Response time is greatly delayed at temperature below the operating temperature range. However, this does not mean the LCD will be out of the order. It will recover when it returns to the specified temperature range.
- 4) If the display area is pushed hard during operation, the display will become abnormal. However, it will return to normal if it is turned off and then back on.
- 5) Condensation on terminals can cause an electrochemical reaction disrupting the terminal circuit. Therefore, it must be used under the relative condition of 40°C , 50% RH.
- 6) When turning the power on, input each signal after the positive/negative voltage becomes stable.

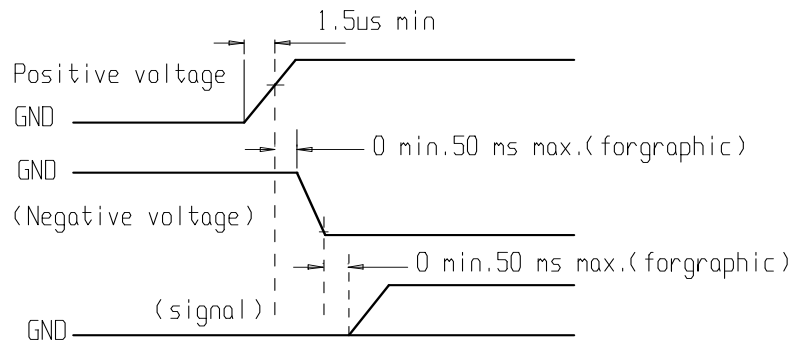

### Safety

- If the LCD panel breaks, be careful not to get the liquid crystal in your mouth. If the liquid crystal touches your skin or clothes, wash it off immediately using soap and plenty of water.

### Handling

- The display panel is made of glass. Do not subject it to a mechanical shock by dropping it or impact.
- If the display panel is damaged and the liquid crystal substance leaks out, be sure not to get any in your mouth. If the substance contacts your skin or clothes, wash it off using soap and water.
- Do not apply excessive force to the display surface or the adjoining areas since this may cause the color tone to vary.
- The polarizer covering the display surface of the LCD module is soft and easily scratched. Handle this polarizer carefully.
- If the display surface becomes contaminated, breathe on the surface and gently wipe it with a soft dry cloth. If it is heavily contaminated, moisten cloth with one of the following solvents :
  - Isopropyl alcohol
  - Ethyl alcohol
- Solvents other than those above-mentioned may damage the polarizer. Especially, do not use the following.
  - Water
  - Ketone
  - Aromatic solvents
- Exercise care to minimize corrosion of the electrode. Corrosion of the electrodes is accelerated by water droplets, moisture condensation or a current flow in a high-humidity environment.
- Install the LCD Module by using the mounting holes. When mounting the LCD module make sure it is free of twisting, warping and distortion. In particular, do not forcibly pull or bend the I/O cable or the backlight cable.
- Do not attempt to disassemble or process the LCD module.
- NC terminal should be open. Do not connect anything.
- If the logic circuit power is off, do not apply the input signals.

- To prevent destruction of the elements by static electricity, be careful to maintain an optimum work environment.
  - Be sure to ground the body when handling the LCD modules.
  - Tools required for assembling, such as soldering irons, must be properly grounded.
  - To reduce the amount of static electricity generated, do not conduct assembling and other work under dry conditions.
  - The LCD module is coated with a film to protect the display surface. Exercise care when peeling off this protective film since static electricity may be generated.

### **Storage**

- When storing the LCD modules, avoid exposure to direct sunlight or to the light of fluorescent lamps
- Store the module in a dark place where the temperature is  $25^{\circ}\text{C} \pm 10^{\circ}\text{C}$  and the humidity below 65% RH.
- Do not store the module near organic solvents or corrosive gases.
- Do not crush, shake, or jolt the module (including accessories).

### **Cleaning**

- Do not wipe the polarizing plate with a dry cloth, as it may scratch the surface.
- Wipe the module gently with soft cloth soaked with a petroleum benzene.
- Do not use ketonic solvents (ketone and acetone) or aromatic solvents (toluene and xylene), as they may damage the polarizing plate.

### **Others:**

- Liquid crystals solidify under low temperature (below the storage temperature range) leading to defective orientation or the generation of air bubbles (black or white). Air bubbles may also be generated if the module is subject to a low temperature.
- If the LCD modules have been operating for a long time showing the same display patterns, the display patterns may remain on the screen as ghost images and a slight contrast irregularity may also appear. A normal operating status can be regained by suspending use for some time. It should be noted that this phenomenon does not adversely affect performance reliability.
- To minimize the performance degradation of the LCD modules resulting from destruction caused by static electricity etc., exercise care to avoid holding the following sections when handling the modules.
  - Exposed area of the printed circuit board.
  - Terminal electrode sections.