



PACIFIC DISPLAY DEVICES

LCD Component Data Sheet **Model Number: 19264-05**

192 x 64 Dot
Graphic LCD Assembly
With KS0107 / KS108 Graphics Controller
LED Backlight

CONTENTS

1.	GENERAL INFORMATION	
1.1	Product Overview	2
1.2	Part Options and Numbering System	2
1.3	Absolute Maximum Ratings	3
1.4	Circuit Block Diagram	3
1.5	Mechanical Characteristics	3
1.6	Input Signal Function	4
1.7	LCM Power, Contrast Control and Bias	4
1.8	LCD Dimensions	5
2.	ELECTRICAL / OPTICAL CHARACTERISTICS	
2.1	DC Electrical Characteristics	6
2.2	AC Electrical Characteristics	7
2.3	Optical Characteristics	9
2.4	LED Backlight Characteristics	10
3.	LCD CONTROLLER CHARACTERISTICS	
3.1	LCD Controller Display and Control Functions (KS0107 / KS0108)	11
3.2	LCD Controller Character Code map	14
4.	RELIABILITY	15
5.	PRECAUTIONS FOR USING LCD MODULES	16

1. GENERAL INFORMATION

1.1 Product Overview

- 192 x 64 dot matrix LCD
- STN (Super Twisted Nematic) or FSTN (Film compensated Super Twisted Nematic) Technology
- KS0108 (or equivalent) Graphics Controller
- Multiplex drive : 1/64 duty, 1/9 bias
- LCD Module Service Life: 100,000 hours minimum

1.2 Part Options and Numbering System

19264	-05	-SL	-F	-ST	-ELED	-GY	-6	
-------	-----	-----	----	-----	-------	-----	----	--

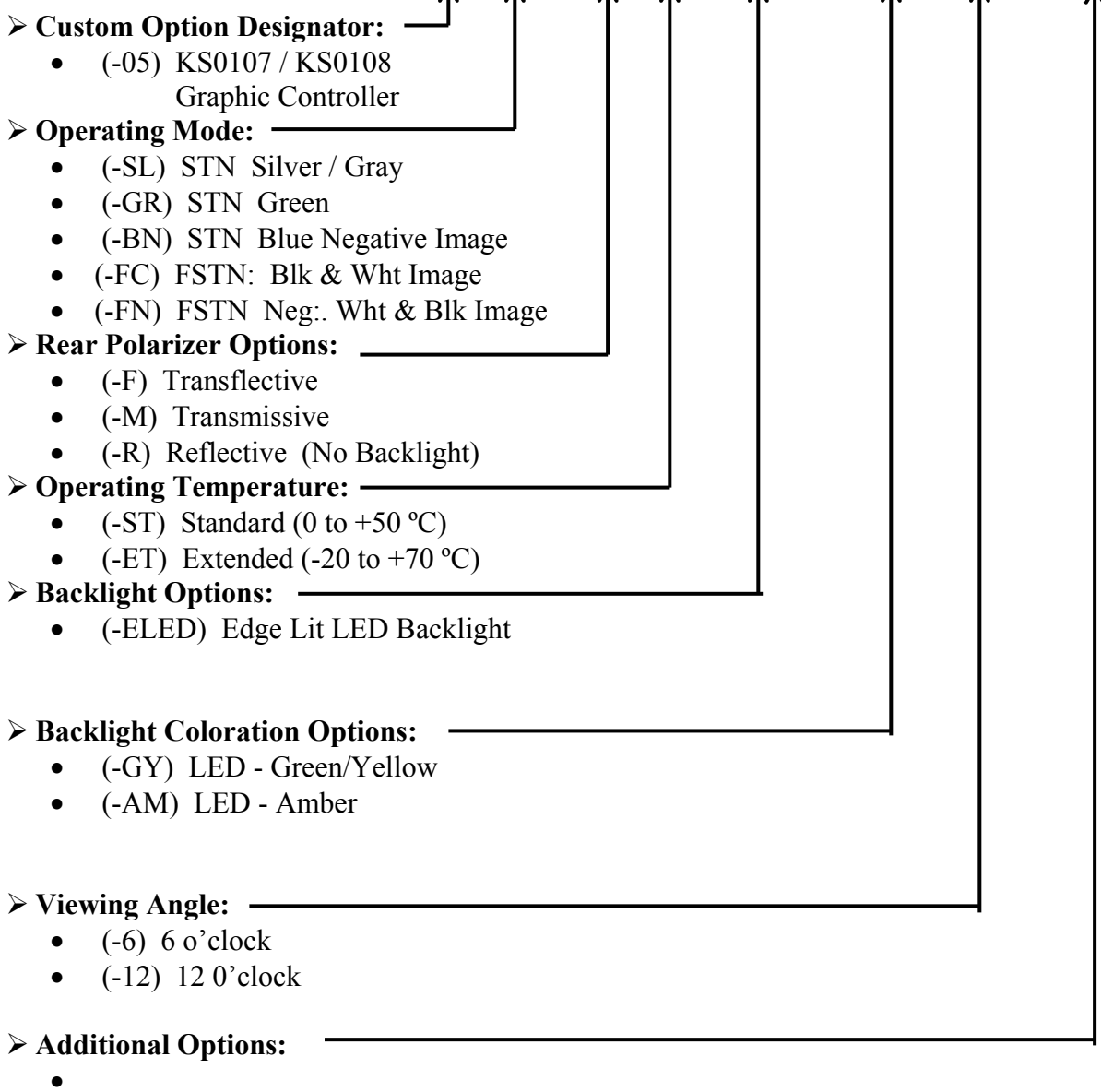

1.3 Absolute Maximum Ratings

Parameter	Symbol	Min	Max	Unit
Supply voltage for logic	V _{DD}	-0.3	7.0	V
Supply voltage for LCD	V _{DD} - V _o	V _{DD} - 19.0	V _{DD} + 0.3	V
Input voltage	V _I	-0.3	V _{DD} + 0.3	V
Standard Operating temperature	TOP (-ST)	0	50	°C
Standard Storage temperature	TST (-ST)	-10	60	°C
Extended Operating temperature	TOP (-ET)	-20	70	°C
Extended Storage temperature	TST (-ET)	-30	80	°C
Soldering Temp	T _{solder}	260		°C

1.4 Circuit Block Diagram

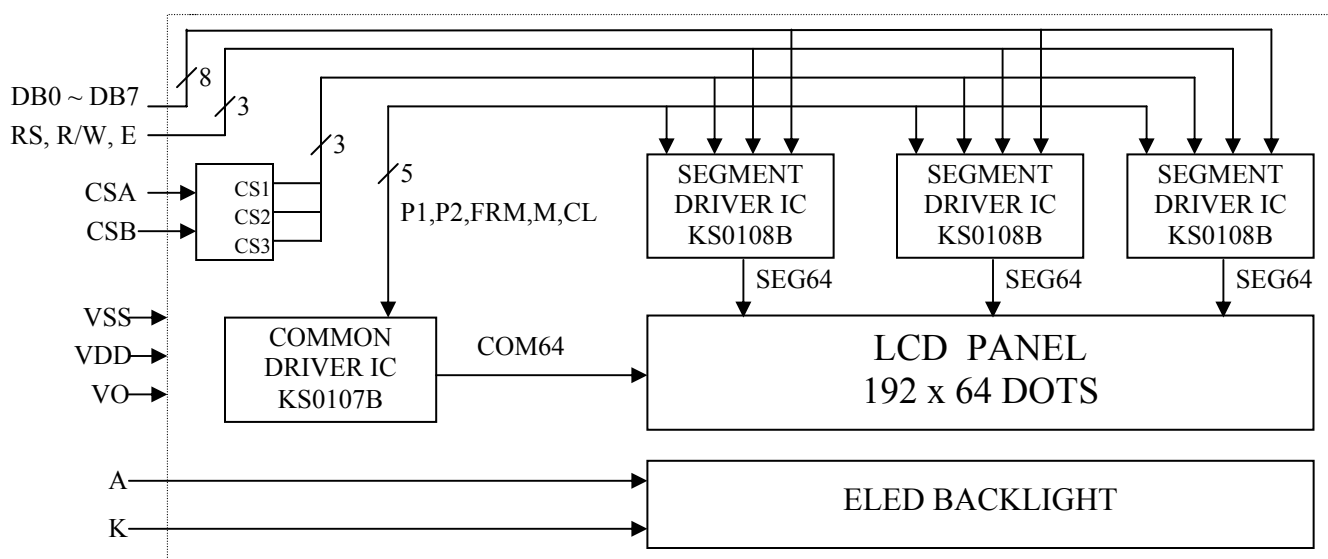

1.5 Mechanical Characteristics

Item	Contents	Unit
Module size (W×H×T)	100.0 x 60.0 x 13.0 Max (ELED Backlight)	mm
Viewing area (W×H)	84.0 x 31.0	mm
Active area (W×H)	78.67 x 26.19	mm
Number of dots	192 x 64	dots
Dot size (W×H)	0.36 x 0.36	mm
Dot pitch (W×H)	0.41 x 0.41	mm

1.6 Input Signal Function

Pin No.	Symbol	Level	Description
1	DB7	H/L	Data bit 7
2	DB6	H/L	Data bit 6
3	DB5	H/L	Data bit 5
4	DB4	H/L	Data bit 4
5	DB3	H/L	Data bit 3
6	DB1	H/L	Data bit 1
7	DB2	H/L	Data bit 2
8	DB0	H/L	Data bit 0
9	E	H, H → L	Chip enable signal
10	R/W	H/L	H : Read mode, L : Write mode
11	RS	H/L	H : Data signal, L : Instruction signal
12	VO	---	Input voltage for LCD
13	VDD	5.0V	Supply voltage for logic
14	VSS	0V	Ground
15	CSA	H/L	Chip select signal for 1 of 3 KS0108B Chips 00=1-64, 01=65-128, 10=129-192
16	CSB	H/L	
17	NC	---	No Connection
18	/RES	L	Reset active low
19	LED-A	4.2V	LED Backlight Anode
20	LED-K	0V	LED Backlight Cathode

1.7 LCM Power, Contrast Control and Bias

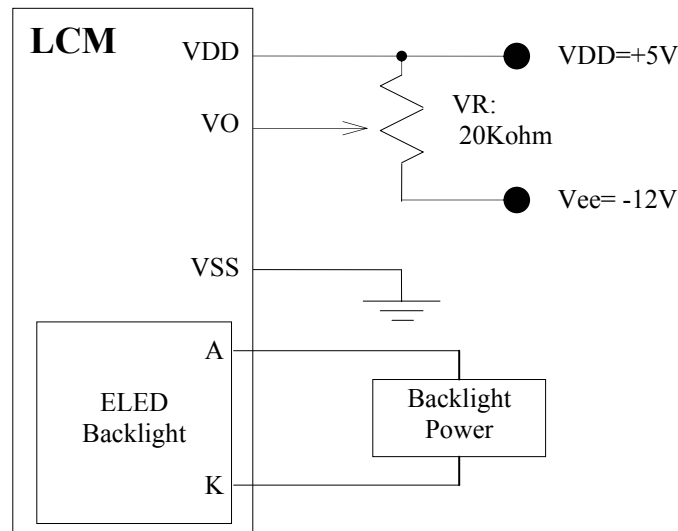

1.8 LCM Dimensions

■ Module Dimensions

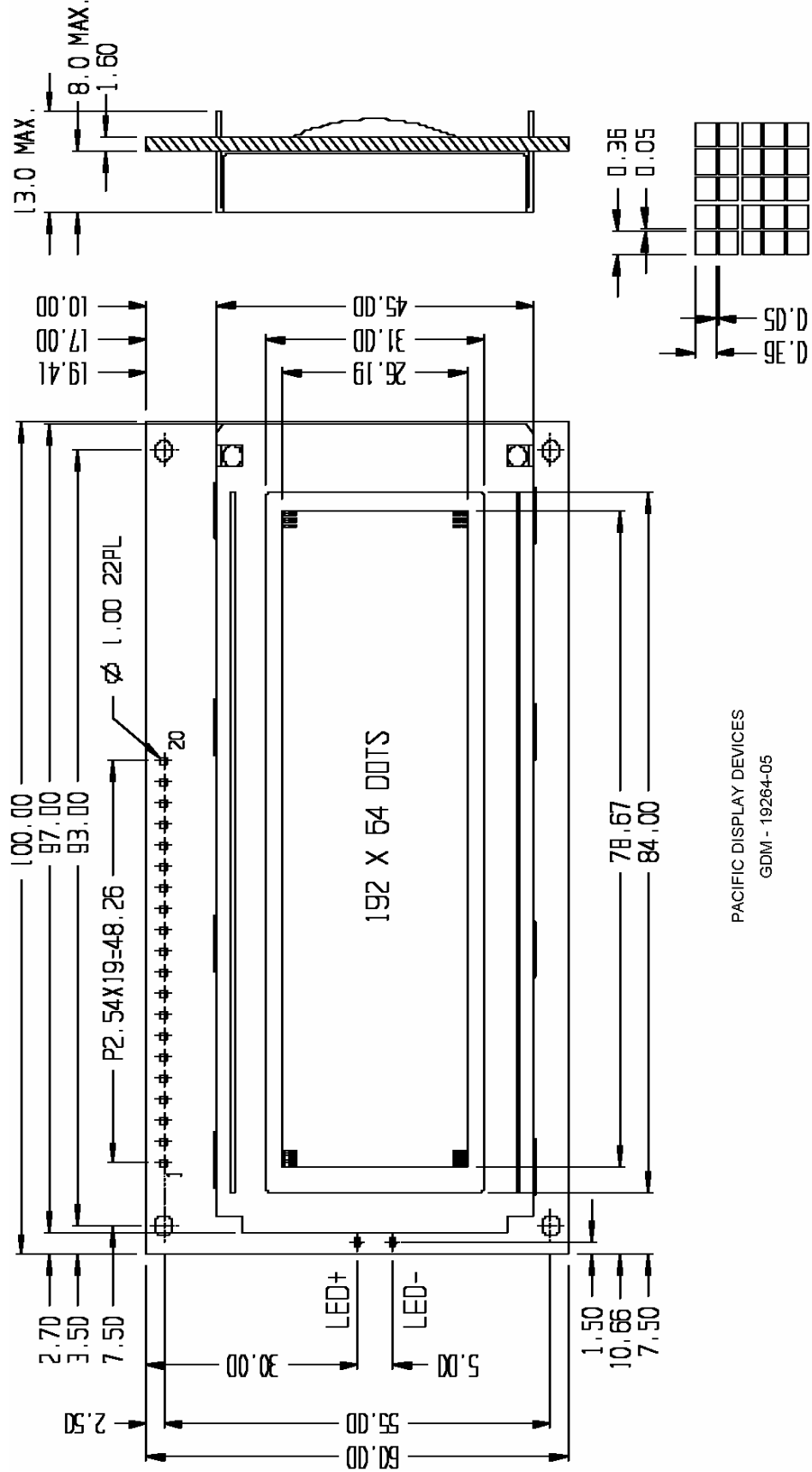

PACIFIC DISPLAY DEVICES
GDM - 19264-05

2. ELECTRICAL / OPTICAL CHARACTERISTICS

2.1 DC Electrical Characteristics (V_{DD} = +5V±10%, V_{SS} = 0V, Ta = 25°C)

Parameter	Symbol	Condition	Min	Typ	Max	Unit
Supply voltage for logic	VDD	---	4.5	5.0	5.5	V
Supply current for logic	IDD	---	---	5.5	10	mA
Operating voltage for LCD	VDD - VO	0°C	14.0	14.7	15.4	V
		25°C	12.3	13.0	13.7	
		50°C	10.9	11.6	12.3	
Input voltage ' H ' level	VIH	---	0.7VDD	---	VDD	V
Input voltage ' L ' level	VIL	---	0	---	0.3VDD	V

■ TIMING OF POWER SUPPLY

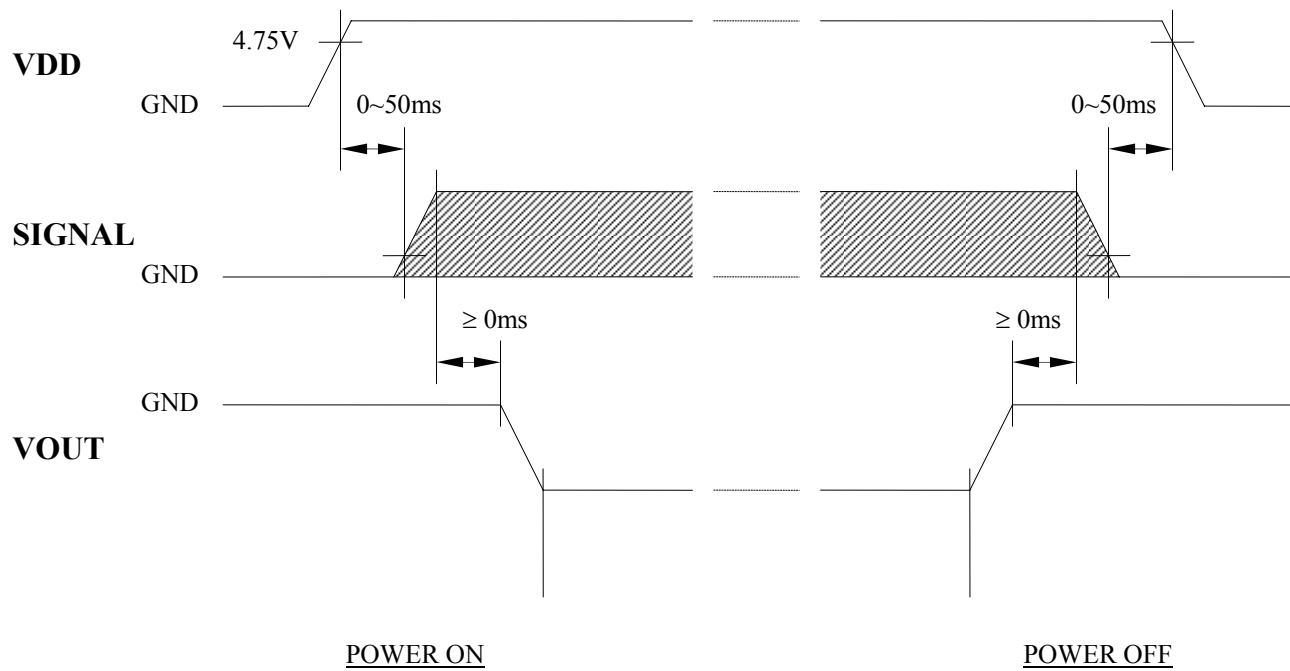

Note : The missing pixels may occur when the LCM is driven except above power supply timing sequence.

2.2 AC Electrical Characteristics

KS 0108 Graphic Controller IC AC Waveform Interface

● MPU Interface

Characteristic	Symbol	Min.	Typ.	Max.	Unit
E cycle	t_{eye}	1000	---	---	ns
E high level width	t_{whE}	450	---	---	ns
E low level width	t_{wlE}	450	---	---	ns
E rise time	t_r	---	---	25	ns
E fall time	t_f	---	---	25	ns
Address set-up time	t_{as}	140	---	---	ns
Address hold time	t_{ah}	10	---	---	ns
Data set-up time	t_{dsw}	200	---	---	ns
Data delay time	t_{ddr}	---	---	320	ns
Data hold time(write)	t_{dhw}	10	---	---	ns
Data hold time(read)	t_{dhr}	20	---	---	ns

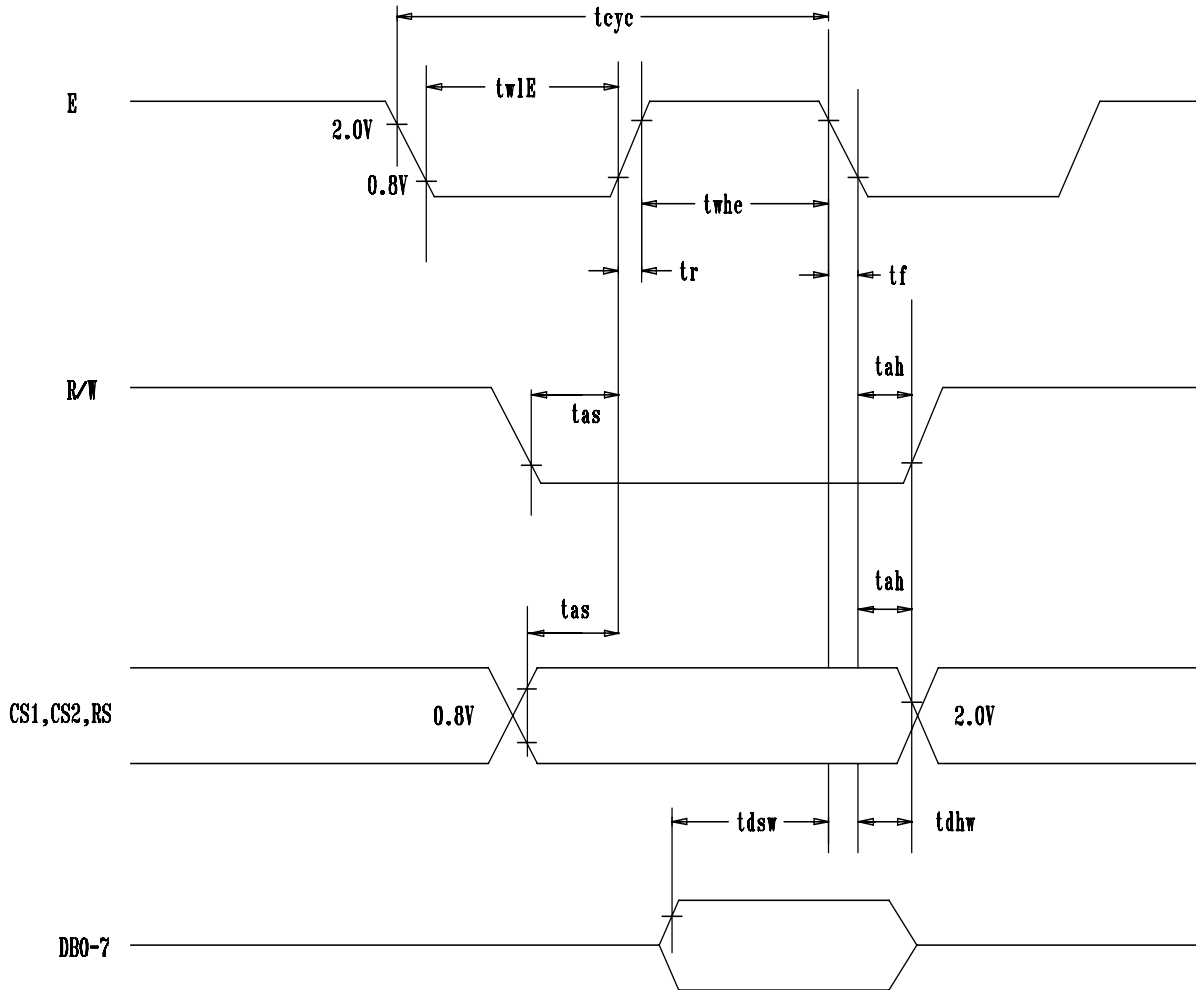

MPU Write Timing

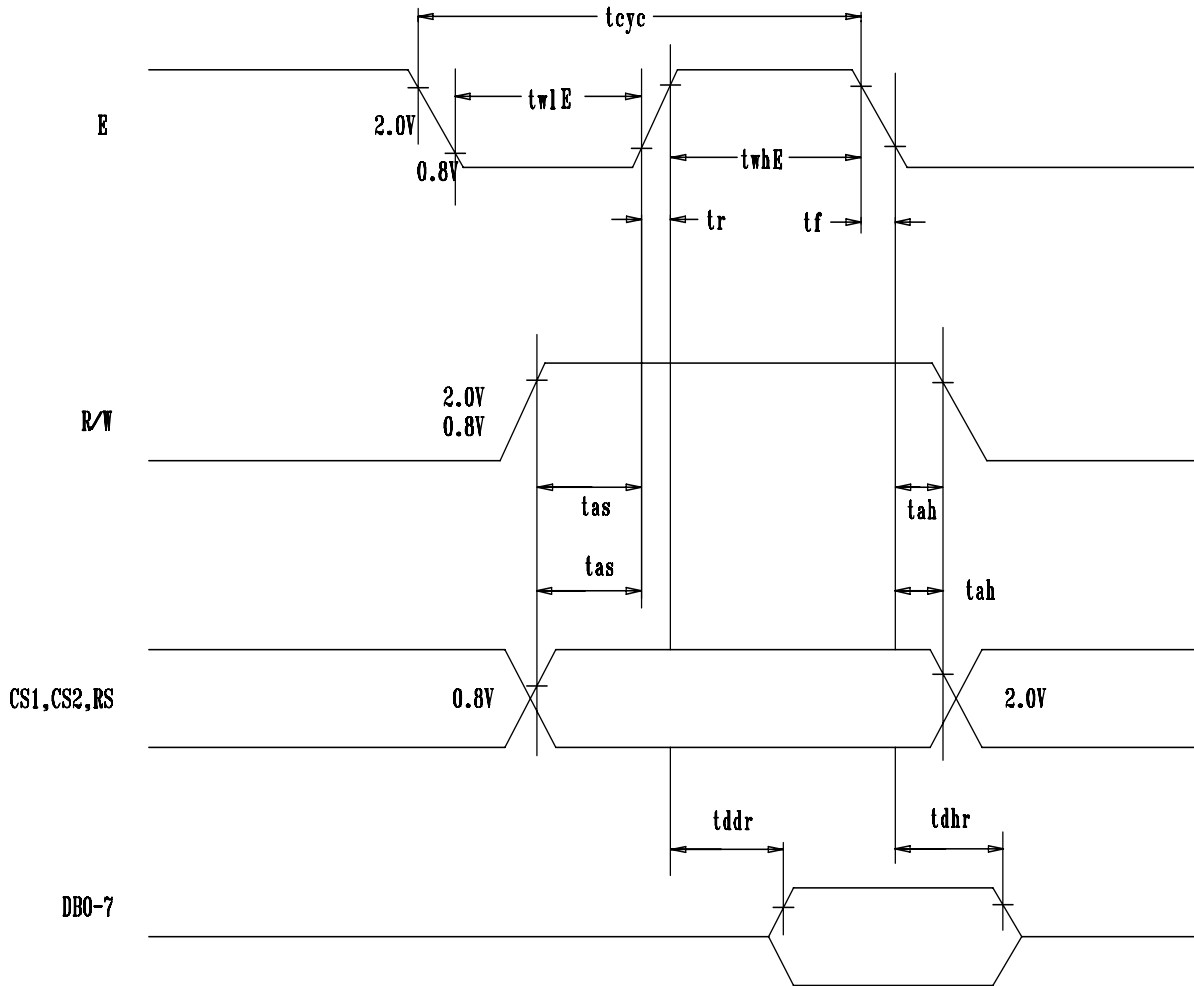

MPU Read Timing

2.3 Optical Characteristics ($V_{OP} = 14.3V, T_a = 25^{\circ}C$)

Item	Symbol	Condition	Min	Typ	Max	Unit	Remarks
Response time	Tr	---	---	244	---	ms	
	Tf		---	121	---	ms	
Contrast ratio	Cr	$\theta=0^{\circ}$ $\phi=0^{\circ}$	---	7.6	---	---	
Viewing angle range	θ	$Cr \geq 2$	24	---	---	deg	$\theta=90$
			24	---	---	deg	$\theta=270$
			43	---	---	deg	$\theta=0$
			26	---	---	deg	$\theta=180$

Note1: Definition of response time.

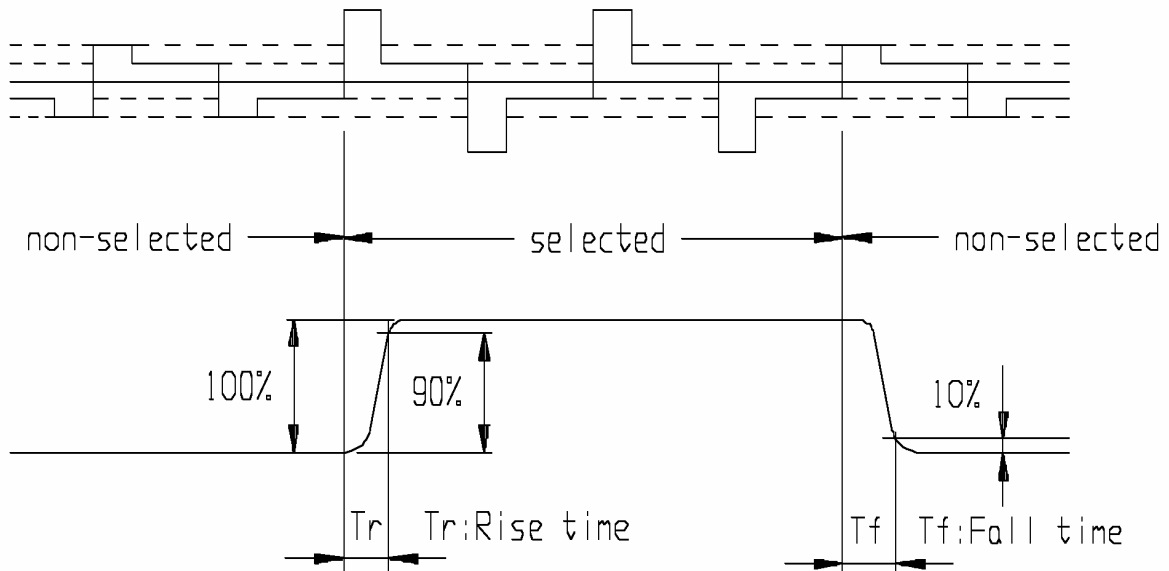

Note2: Definition of contrast ratio 'Cr' .

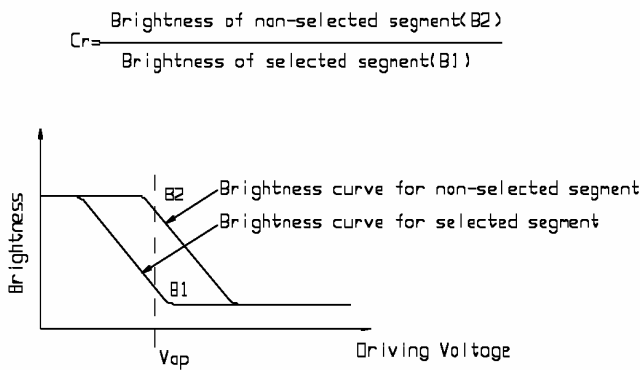

Note3: Definition of viewing angle range ' θ '.

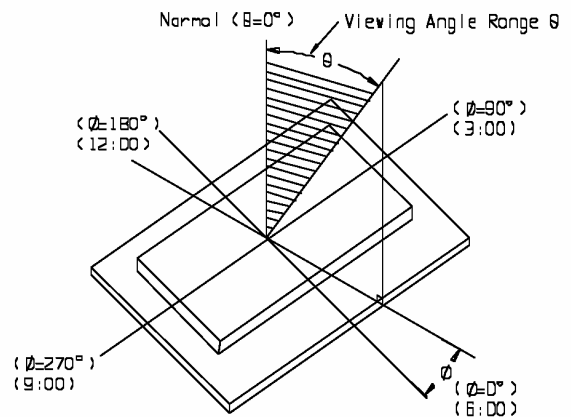

2.4 LED Backlight Characteristics

■ Yellow-Green LED Operating Characteristics (Array Lit)

Item	Symbol	Conditions	Standard			Unit
			Min.	Typ.	Max.	
Forward voltage	V_f	---	3.9	4.2	4.6	VDC
Forward Current	I_F	---	---	71	170	mA

Item	Conditions	Standard		Unit
		Min.	Max.	
Life	$T_a = 25\text{ }^\circ\text{C}$	100,000	---	hrs

3. OPERATING PRINCIPALS AND METHODS

3.1 LCD Controller Display and Control Functions (KS0108 Controller)

■ I/O Buffer

Input buffer controls the status between the enable and disable of chip. Unless the CS1 or CS2 is in active mode, input or output of data and instruction do not execute. Therefore internal state is not change. But RSTB can operate regardless of CS1 and CS2.

■ Input Register

Input register is provided to interface with MPU which is different operating frequency. Input register stores the data temporarily before writing it into display data RAM.

When CS1 or CS2 is in the active mode, R/W and RS select the input register. The data from MPU is written into input register and then write it into display data RAM. Data is latched when falling of the E signal and written automatically into the display data RAM by internal operation.

■ Output Register

Output register stores the data temporarily from display data RAM when CS1 or CS2 is in active mode and R/W and RS = H. Stored data in display data RAM is latched in output register. When CS1 or CS2 is in active mode and R/W = H, RS = L, status data (busy check) can be read out.

To read the contents of display data RAM, twice access of read instruction is needed. In first access, data in display data RAM is latched into output register. In second access, MPU can read data which is latched. That is, to read the data in display data RAM, it needs dummy read. But status read does not need dummy read.

RS	R/W	Function
0	0	Instruction
	1	Status read (busy check)
1	0	Data write (from input register to display data RAM)
	1	Data read (from display data RAM to output register)

■ Reset

System reset can be initialized by setting RST terminal at low level when turning power on, receiving instruction from MPU. When RST becomes low, following procedure is occurred.

1. Display off
2. Display start line register become set by 0. (Z-address 0)

While RST is low level, no instruction except status read can be accepted. Reset status appears at DB4. After DB4 is low, any instruction can be accepted.

The Conditions of power supply at initial power up are shown in table 1.

Table 1. Power Supply Initial Conditions

Item	Symbol	Min.	Typ.	Max.	Unit
Reset time	t_{RST}	1.0	---	---	us
Rise time	t_r	---	---	200	ns

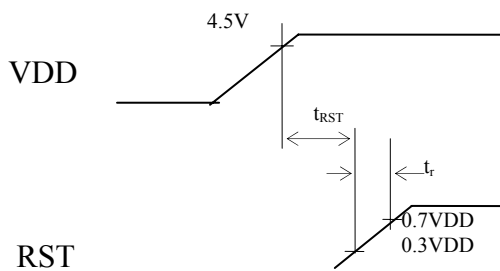

■ **Busy Flag**

Busy flag indicates that KS0108B is operating or not operating. When busy flag is high, KS0108B is in internal operating. When busy flag is low, KS0108B can accept the data or instruction.

DB7 indicates busy flag of the KS0108B.

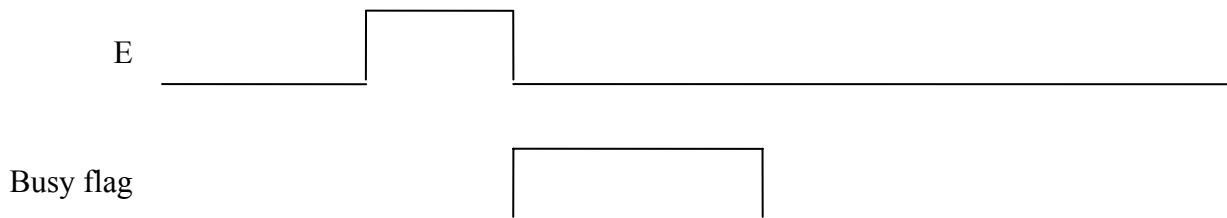

■ **Display On/Off Flip-Flop**

The display on/off flip-flop makes on/off of the liquid crystal display. When flip-flop is reset (logical low), selective voltage or non selective voltage appears on segment output terminals. When flip-flop is set (logical high), non selective voltage appears on segment output terminals regardless of display RAM data.

The display on/off flip-flop can changes status by instruction. The display data at all segment disappear while RSTB is low. The status of the flip-flop is output to DB5 by status read instruction.

■ **X Page Register**

X page register designates page of the internal display data RAM. It has not count function. An address is set by instruction.

■ **Y Address Counter**

Y address counter designates address of the internal display data RAM. An address is set by instruction and is increased by 1 automatically by read or write operations of display data.

■ **Display Data RAM**

Display data RAM stores a display data for liquid crystal display. To express on state of dot matrix of liquid crystal display, write data 1. The other way, off state writes 0.

DB<0:7>=0 → Y address 0 → S1

DB<0:7>=63 → Y address 63 → S64

■ **Display Start Line Register**

The display start line register indicates address of display data RAM to display top line of liquid crystal display. Bit data (DB<0:5>) of the display start line set instruction is latched in display start line register. It is used for scrolling of the liquid crystal display screen.

■ **Display Control Instruction**

The display control instructions control the internal state of the KS0108B. Instruction is received from MPU to KS0108B for the display control. The following table shows various instructions.

Instruction	RS	R/W	DB7	DB6	DB5	DB4	DB3	DB2	DB1	DB0	Function	
Display ON/OFF	0	0	0	0	1	1	1	1	1	0/1	Controls the display on or off. Internal status and display RAM data are not affected. 0:OFF, 1:ON	
Set Address	0	0	0	1	Y address (0~63)						Sets the Y address in the Y address counter.	
Set Page (X address)	0	0	1	0	1	1	1	Page (0~7)			Sets the X address at the X address register.	
Display Start Line	0	0	1	1	Display start line (0~63)						Indicates the display data RAM displayed at the top of the screen.	
Status Read	0	1	B U S Y	0	O N / O F F	R E S E T	0	0	0	0	Read status. BUSY 0 : Ready 1 : In operation ON/OFF 0 : Display ON 1 : Display OFF RESET 0 : Normal 1 : Reset	
Write Display Data	1	0	Write Data									Writes data (DB0:7) into display data RAM. After writing instruction, Y address is increased by 1 automatically.
Read Display Data	1	1	Read Data									Reads data (DB0:7) from display data RAM to the data bus.

3.2 LCD Controller Character Code Map

PAGE ADDRESS	DISPLAY DATA	1ST KS0108B					2ND KS0108B					LINE ADDRESS	COMMON										
B8	D 0	█	█	█	█	---	---	---	---	---	---	C 0	COM 0										
	D 1	█	█	█	█	---	---	---	---	---	---	C 1	COM 1										
	D 2	█	█	█	█	---	---	---	---	---	---	C 2	COM 2										
	D 3	█	█	█	█	---	---	---	---	---	---	C 3	COM 3										
	D 4	█	█	█	█	---	---	---	---	---	---	C 4	COM 4										
	D 5	█	█	█	█	---	---	---	---	---	---	C 5	COM 5										
	D 6	█	█	█	█	---	---	---	---	---	---	C 6	COM 6										
	D 7	█	█	█	█	---	---	---	---	---	---	C 7	COM 7										
B9	D 0					---	---	---	---	---	---	C 8	COM 8										
	D 1					---	---	---	---	---	---	C 9	COM 9										
	D 2					---	---	---	---	---	---	C A	COM 10										
	D 3					---	---	---	---	---	---	C B	COM 11										
	D 4					---	---	---	---	---	---	C C	COM 12										
	D 5					---	---	---	---	---	---	C D	COM 13										
	D 6					---	---	---	---	---	---	C E	COM 14										
	D 7					---	---	---	---	---	---	C F	COM 15										
BA	D 0					---	---	---	---	---	---	D 0	COM 16										
	D 1					---	---	---	---	---	---	D 1	COM 17										
	D 2					---	---	---	---	---	---	D 2	COM 18										
	D 3					---	---	---	---	---	---	D 3	COM 19										
	D 4					---	---	---	---	---	---	D 4	COM 20										
	D 5					---	---	---	---	---	---	D 5	COM 21										
	D 6					---	---	---	---	---	---	D 6	COM 22										
	D 7					---	---	---	---	---	---	D 7	COM 23										
BB	D 0					---	---	---	---	---	---	D 8	COM 24										
	D 1					---	---	---	---	---	---	D 9	COM 25										
	D 2					---	---	---	---	---	---	D A	COM 26										
	D 3					---	---	---	---	---	---	D B	COM 27										
	D 4					---	---	---	---	---	---	D C	COM 28										
	D 5					---	---	---	---	---	---	D D	COM 29										
	D 6					---	---	---	---	---	---	D E	COM 30										
	D 7					---	---	---	---	---	---	D F	COM 31										
BC	D 0					---	---	---	---	---	---	E 0	COM 32										
	D 1					---	---	---	---	---	---	E 1	COM 33										
	D 2					---	---	---	---	---	---	E 2	COM 34										
	D 3					---	---	---	---	---	---	E 3	COM 35										
	D 4					---	---	---	---	---	---	E 4	COM 36										
	D 5					---	---	---	---	---	---	E 5	COM 37										
	D 6					---	---	---	---	---	---	E 6	COM 38										
	D 7					---	---	---	---	---	---	E 7	COM 39										
BD	D 0					---	---	---	---	---	---	E 8	COM 40										
	D 1					---	---	---	---	---	---	E 9	COM 41										
	D 2					---	---	---	---	---	---	E A	COM 42										
	D 3					---	---	---	---	---	---	E B	COM 43										
	D 4					---	---	---	---	---	---	E C	COM 44										
	D 5					---	---	---	---	---	---	E D	COM 45										
	D 6					---	---	---	---	---	---	E E	COM 46										
	D 7					---	---	---	---	---	---	E F	COM 47										
BE	D 0					---	---	---	---	---	---	F 0	COM 48										
	D 1					---	---	---	---	---	---	F 1	COM 49										
	D 2					---	---	---	---	---	---	F 2	COM 50										
	D 3					---	---	---	---	---	---	F 3	COM 51										
	D 4					---	---	---	---	---	---	F 4	COM 52										
	D 5					---	---	---	---	---	---	F 5	COM 53										
	D 6					---	---	---	---	---	---	F 6	COM 54										
	D 7					---	---	---	---	---	---	F 7	COM 55										
BF	D 0					---	---	---	---	---	---	F 8	COM 56										
	D 1					---	---	---	---	---	---	F 9	COM 57										
	D 2					---	---	---	---	---	---	F A	COM 58										
	D 3					---	---	---	---	---	---	F B	COM 59										
	D 4					---	---	---	---	---	---	F C	COM 60										
	D 5					---	---	---	---	---	---	F D	COM 61										
	D 6					---	---	---	---	---	---	F E	COM 62										
	D 7					---	---	---	---	---	---	F F	COM 63										
	COLUMN ADDRESS	40	41	42	43	44	45	---	---	---	---	7F	40	---	---	---	---	---	---	---	---	7F	
	SEGMENT	SEG 0	SEG 1	SEG 2	SEG 3	SEG 4	SEG 5	---	---	---	---	---	---	---	---	---	---	---	---	---	---	---	---
													SEG 63	SEG 64									

4. RELIABILITY

Environmental Test				
No	Test Item	Content of Test	Test Condition	Applicable Standard
1	High temperature storage	Endurance test applying the high storage temperature for a long time.	60 °C 200 hrs	-----
2	Low temperature storage	Endurance test applying the low storage temperature for a long time.	-10 °C 200 hrs	-----
3	High temperature operation	Endurance test applying the electric stress (Voltage & Current) and the thermal stress to the element for a long time.	50 °C 200 hrs	-----
4	Low temperature operation	Endurance test applying the electric stress under low temperature for a long time.	0 °C 200 hrs	-----
5	High temperature / Humidity storage	Endurance test applying the high temperature and high humidity storage for a long time.	60 °C , 90 %RH 96 hrs	MIL-202E-103B JIS-C5023
6	High temperature / Humidity operation	Endurance test applying the electric stress (Voltage & Current) and temperature / humidity stress to the element for a long time.	40 °C , 90 %RH 96 hrs	MIL-202E-103B JIS-C5023
7	Temperature cycle	Endurance test applying the low and high temperature cycle. $\begin{array}{c} -20^{\circ}\text{C} \quad 25^{\circ}\text{C} \quad 70^{\circ}\text{C} \\ 30\text{min} \quad \rightleftharpoons \quad 5\text{min.} \quad \rightleftharpoons \quad 30\text{min} \\ \leftarrow \hspace{10em} \hspace{10em} \rightarrow \\ \text{1 cycle} \end{array}$	-10°C / 60°C 10 cycles	-----
Mechanical Test				
8	Vibration test	Endurance test applying the vibration during transportation and using.	10~22Hz → 1.5mmp-p 22~500Hz → 1.5G Total 0.5hrs	MIL-202E-201A JIS-C5025 JIS-C7022-A-10
9	Shock test	Constructional and mechanical endurance test applying the shock during transportation.	50G Half sign wave 11 msdc 3 times of each direction	MIL-202E-213B
10	Atmospheric pressure test	Endurance test applying the atmospheric pressure during transportation by air.	115 mbar 40 hrs	MIL-202E-105C
Others				
11	Static electricity test	Endurance test applying the electric stress to the terminal.	VS=800V , RS=1.5 kΩ CS=100 pF 1 time	MIL-883B-3015.1

*** Supply voltage for logic system = VDD. Supply voltage for LCD system = Operating voltage at 25°C

■ LCD Panel Service Life

Definition of panel service life

- 100,000 hours minimum at 25° C ±10%
- Contrast becomes 30% of initial value
- Current consumption becomes three times higher than initial value
- Remarkable alignment deterioration occurs in LCD cell layer
- Unusual operation occurs in display functions

5. PRECAUTIONS FOR USING LCD MODULES

Installing LCD Modules

The hole in the printed circuit board is used to fix LCM as shown in the picture below. Attend to the following items when installing the LCM.

- 1) Cover the surface with a transparent protective plate to protect the polarizer and LC cell.

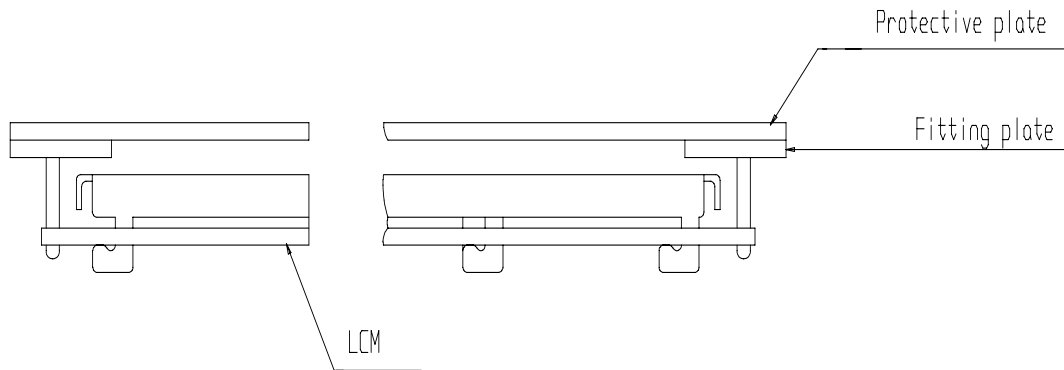

- 2) When assembling the LCM into other equipment, the spacer to the bit between the LCM and the fitting plate should have enough height to avoid causing stress to the module surface, refer to the individual specifications for measurements. The measurement tolerance should be ± 0.1 mm.

Precaution for Handling LCD Modules

Since LCM has been assembled and adjusted with a high degree of precision, avoid applying excessive shocks to the module or making any alterations or modifications to it.

- 1) Cover the surface with a transparent protective plate to protect the polarizer and LC cell.
- 2) Do not alter, modify or change the shape of the tab on the metal frame.
- 3) Do not make extra holes on the printed circuit board, modify its shape or change the positions of components to be attached.
- 4) Do not damage or modify the pattern writing on the printed circuit board.
- 5) Absolutely do not modify the zebra rubber strip (conductive rubber) or heat seal connector.
- 6) Except for soldering the interface, do not make any alterations or modifications with a soldering iron.
- 7) Do not drop, bend or twist LCM.

Electro-Static Discharge Control

Since this module uses a CMOS LSI, the same careful attention should be paid to electrostatic discharge as for an ordinary CMOS IC.

- 1) Make certain that you are grounded when handling LCM.
- 2) Before remove LCM from its packing case or incorporating it into a set, be sure the module and your body have the same electric potential.
- 3) When soldering the terminal of LCM, make certain the AC power source for the soldering iron does not leak.
- 4) When using an electric screwdriver to attach LCM, the screwdriver should be of ground potentiality to minimize as much as possible any transmission of electromagnetic waves produced sparks coming from the commutator of the motor.
- 5) As far as possible make the electric potential of your work clothes and that of the work bench the ground potential.
- 6) To reduce the generation of static electricity be careful that the air in the work is not too dried. A relative humidity of 50%-60% is recommended.

Precaution for soldering to the LCM

- 1) Observe the following when soldering lead wire, connector cable and etc. to the LCM.
 - a) Soldering iron temperature : $280^{\circ}\text{C} \pm 10^{\circ}\text{C}$.
 - b) Soldering time : 3-4 sec.
- 2) Solder : eutectic solder.

- 3) If soldering flux is used, be sure to remove any remaining flux after finishing to soldering operation. (This does not apply in the case of a non-halogen type of flux.) It is recommended that you protect the LCD surface with a cover during soldering to prevent any damage due to flux spatters.
- 4) When soldering the electroluminescent panel and PC board, the panel and board should not be detached more than three times. This maximum number is determined by the temperature and time conditions mentioned above, though there may be some variance depending on the temperature of the soldering iron.
- 5) When remove the electroluminescent panel from the PC board, be sure the solder has completely melted, the soldered pad on the PC board could be damaged.

Precautions for Operation

- 1) Viewing angle varies with the change of liquid crystal driving voltage (VO). Adjust VO to show the best contrast.
- 2) Driving the LCD in the voltage above the limit shortens its life.
- 3) Response time is greatly delayed at temperature below the operating temperature range. However, this does not mean the LCD will be out of the order. It will recover when it returns to the specified temperature range.
- 4) If the display area is pushed hard during operation, the display will become abnormal. However, it will return to normal if it is turned off and then back on.
- 5) Condensation on terminals can cause an electrochemical reaction disrupting the terminal circuit. Therefore, it must be used under the relative condition of 40°C , 50% RH.
- 6) When turning the power on, input each signal after the positive/negative voltage becomes stable.

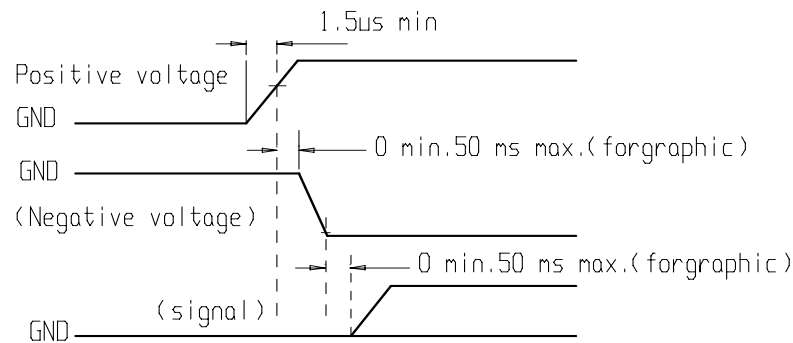

Safety

- If the LCD panel breaks, be careful not to get the liquid crystal in your mouth. If the liquid crystal touches your skin or clothes, wash it off immediately using soap and plenty of water.

Handling

- The display panel is made of glass. Do not subject it to a mechanical shock by dropping it or impact.
- If the display panel is damaged and the liquid crystal substance leaks out, be sure not to get any in your mouth. If the substance contacts your skin or clothes, wash it off using soap and water.
- Do not apply excessive force to the display surface or the adjoining areas since this may cause the color tone to vary.
- The polarizer covering the display surface of the LCD module is soft and easily scratched. Handle this polarizer carefully.
- If the display surface becomes contaminated, breathe on the surface and gently wipe it with a soft dry cloth. If it is heavily contaminated, moisten cloth with one of the following solvents :
 - Isopropyl alcohol
 - Ethyl alcohol
- Solvents other than those above-mentioned may damage the polarizer. Especially, do not use the following.
 - Water
 - Ketone
 - Aromatic solvents
- Exercise care to minimize corrosion of the electrode. Corrosion of the electrodes is accelerated by water droplets, moisture condensation or a current flow in a high-humidity environment.
- Install the LCD Module by using the mounting holes. When mounting the LCD module make sure it is free of twisting, warping and distortion. In particular, do not forcibly pull or bend the I/O cable or the backlight cable.
- Do not attempt to disassemble or process the LCD module.
- NC terminal should be open. Do not connect anything.
- If the logic circuit power is off, do not apply the input signals.

- To prevent destruction of the elements by static electricity, be careful to maintain an optimum work environment.
 - Be sure to ground the body when handling the LCD modules.
 - Tools required for assembling, such as soldering irons, must be properly grounded.
 - To reduce the amount of static electricity generated, do not conduct assembling and other work under dry conditions.
 - The LCD module is coated with a film to protect the display surface. Exercise care when peeling off this protective film since static electricity may be generated.

Storage

- When storing the LCD modules, avoid exposure to direct sunlight or to the light of fluorescent lamps
- Store the module in a dark place where the temperature is $25^{\circ}\text{C} \pm 10^{\circ}\text{C}$ and the humidity below 65% RH.
- Do not store the module near organic solvents or corrosive gases.
- Do not crush, shake, or jolt the module (including accessories).

Cleaning

- Do not wipe the polarizing plate with a dry cloth, as it may scratch the surface.
- Wipe the module gently with soft cloth soaked with a petroleum benzene.
- Do not use ketonic solvents (ketone and acetone) or aromatic solvents (toluene and xylene), as they may damage the polarizing plate.

Others:

- Liquid crystals solidify under low temperature (below the storage temperature range) leading to defective orientation or the generation of air bubbles (black or white). Air bubbles may also be generated if the module is subject to a low temperature.
- If the LCD modules have been operating for a long time showing the same display patterns, the display patterns may remain on the screen as ghost images and a slight contrast irregularity may also appear. A normal operating status can be regained by suspending use for some time. It should be noted that this phenomenon does not adversely affect performance reliability.
- To minimize the performance degradation of the LCD modules resulting from destruction caused by static electricity etc., exercise care to avoid holding the following sections when handling the modules.
 - Exposed area of the printed circuit board.
 - Terminal electrode sections.