



PACIFIC DISPLAY DEVICES

LCD Component Data Sheet

Model Number: 320240-04

320 x 240 Dot

FSTN Graphic LCD Assembly

With Row and Column Drivers

Compact Design , Optional EL Panel Backlight & Touch Screen Assembly

CONTENTS

1.	GENERAL INFORMATION	
1.1	Product Overview	2
1.2	Part Numbering System	2
1.3	Absolute Maximum Ratings	3
1.4	Circuit Block Diagram	3
1.5	Mechanical Characteristics	3
1.6	Input Signal Function	4
1.7	LCM Power, Contrast Control and Bias	4
1.8	LCD Dimensions	5
1.9	LCD External Interface Interconnections	6
1.10	LCD Schematic	7
2.	ELECTRICAL / OPTICAL CHARACTERISTICS	
2.1	DC Electrical Characteristics	8
2.2	AC Electrical Characteristics	9
2.3	Optical Characteristics	12
2.4	ELP Backlight Characteristics	13
2.5	Optional Touch Panel Characteristics	14
4.	RELIABILITY	15
5.	PRECAUTIONS FOR USING LCD MODULES	16

1. GENERAL INFORMATION

1.1 Product Overview

- 320 x 240 dot matrix LCD
- FSTN (Film Compensated Super Twisted Nematic) and STN Technology
- LH1560 / LH1562 or NT7701 / NT7702 or equivalent Row and Column Driver ICs.
- Multiplex drive : 1/240 duty, 1/13 bias
- Compact Design with Optional EL Panel backlight and Touch Screen
- LCD Module Service Life: 100,000 hours minimum

1.2 Part Numbering System

320240	-04	-FC	-F	-ST	-ELP	-BL	-12	-TS
---------------	------------	------------	-----------	------------	-------------	------------	------------	------------

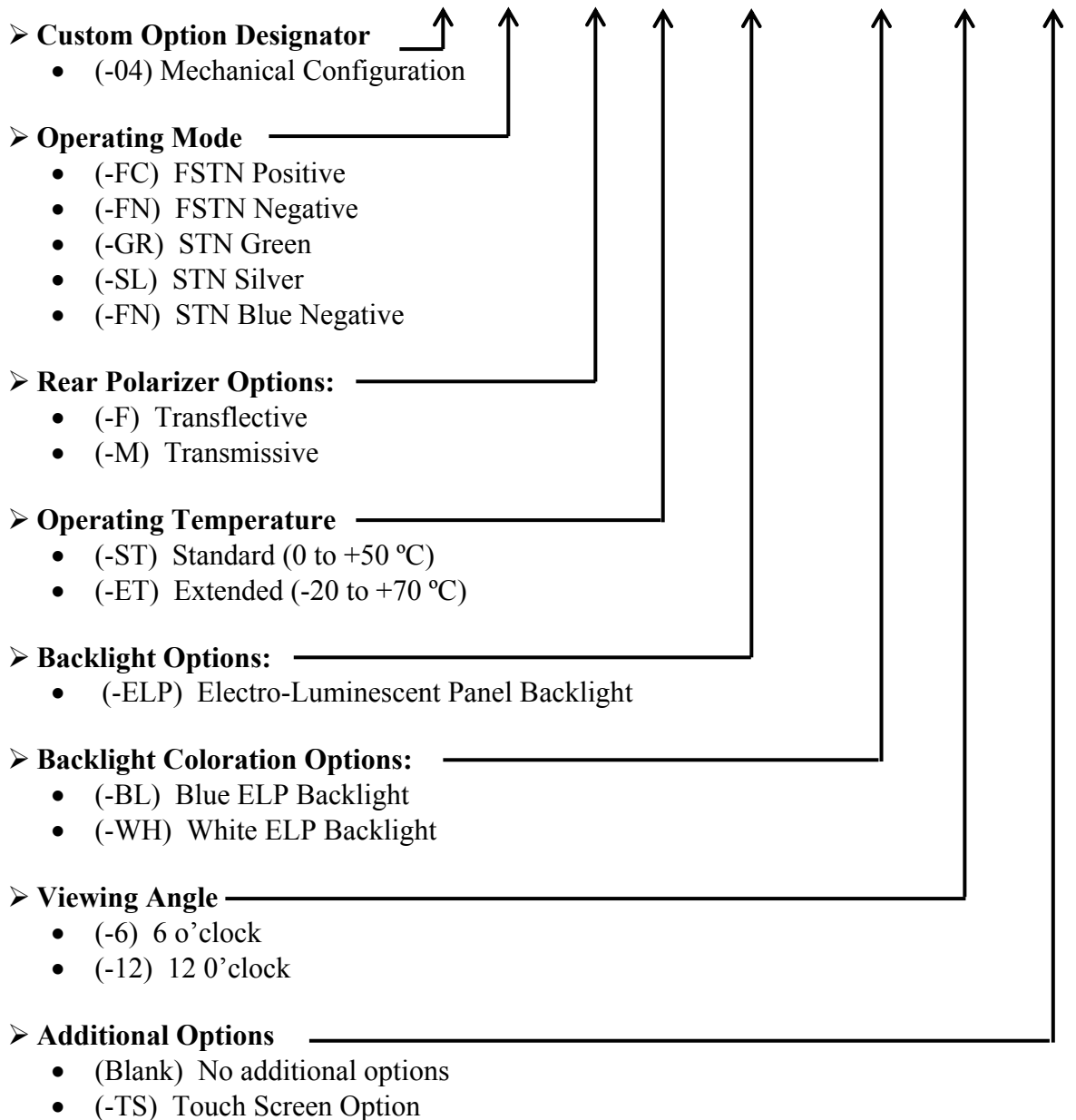

1.3 Absolute Maximum Ratings (Ta = 25°C)

Parameter	Symbol	Min	Max	Unit
Supply voltage for logic	V _{DD}	-0.3	+7.0	V
*Supply voltage for LCD	V _{EE}	-0.3	+45.0	V
Input voltage	V _I	-0.3	V _{DD} +0.3	V
Standard Operating temperature	TOP (-ST)	0	50	°C
Standard Storage temperature	TST (-ST)	-10	60	°C
Extended Operating temperature	TOP (-ET)	-20	70	°C
Extended Storage temperature	TST (-ET)	-30	80	°C
Soldering Temp	T _{solder}	260		°C

*NOTE: V_{EE} is a positive voltage, and a negative voltage on V_{EE} will damage the display

1.4 Circuit Block Diagram

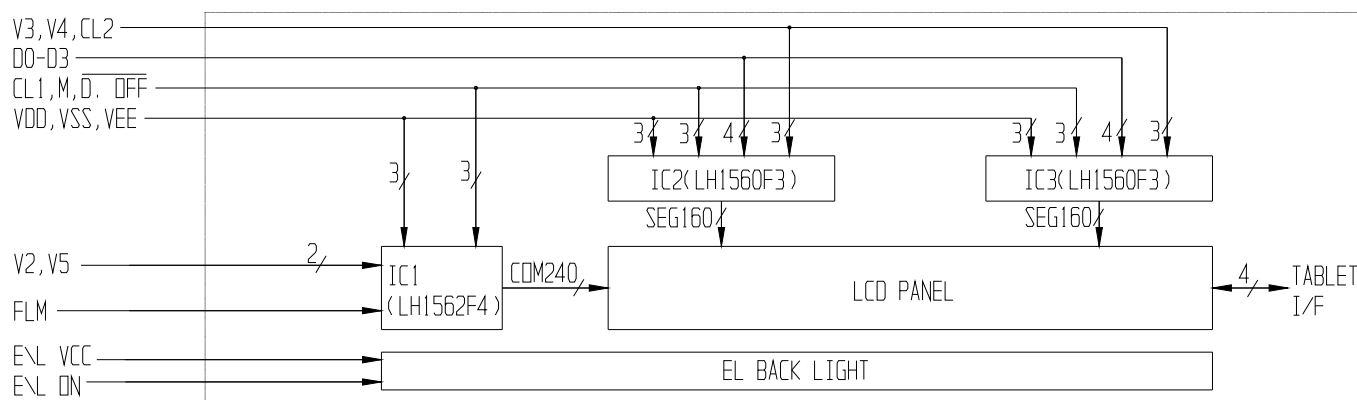

1.5 Mechanical Characteristics

Item	Contents	Unit
Module size (W×H×T)	70.5 x 89 x 7.3 Max	mm
Viewing area (W×H)	61.1 x 80.55	mm
Number of dots	320 x 240	dots
Dot size (W×H)	0.225 x 0.225	mm
Dot pitch (W×H)	0.24 x 0.24	mm

1.6 Input Signal Function

■ FPC Connector

Pin No.	Symbol	Level	Description
1	NC	---	No connection
2	NC	---	No connection
3	V _{EE}	+20.8V	Power supply pin for LCD bias voltage (Contrast)
4	V _{DD}	+5V	Logic system power supply pin
5	FLM	H/L	Frame signal pin
6	V _{SS}	0V	Ground
7	CL1	H/L	Latch pulse input pin for display data
8	V _{SS}	0V	Ground
9	M	H/L	AC signal input for LCD driving waveform
10	/D.OFF	L	Control input pin for output deselect level
11	CL2	H/L	Clock input pin for taking display data
12	NC	---	No connection
13	NC	---	No connection
14	D3	H/L	Data bit 4
15	D2	H/L	Data bit 3
16	D1	H/L	Data bit 2
17	D0	H/L	Data bit 1
18	NC	---	No connection
19	T/P (X2)	---	Touch Panel – X2 Lead (Optional)
20	T/P (Y1)	---	Touch Panel – Y1 Lead (Optional)
21	T/P (X1)	---	Touch Panel – X1 Lead (Optional)
22	T/P (Y2)	---	Touch Panel – Y2 Lead (Optional)
23	EL-PWR	AC	EL light AC supply pin
24	EL-PWR	AC	EL light AC supply pin

Note: See LH1560 / LH1562 or NT7701 / NT7702 data sheets for better pin functionality definition

1.7 LCM Power, Contrast Control and Bias

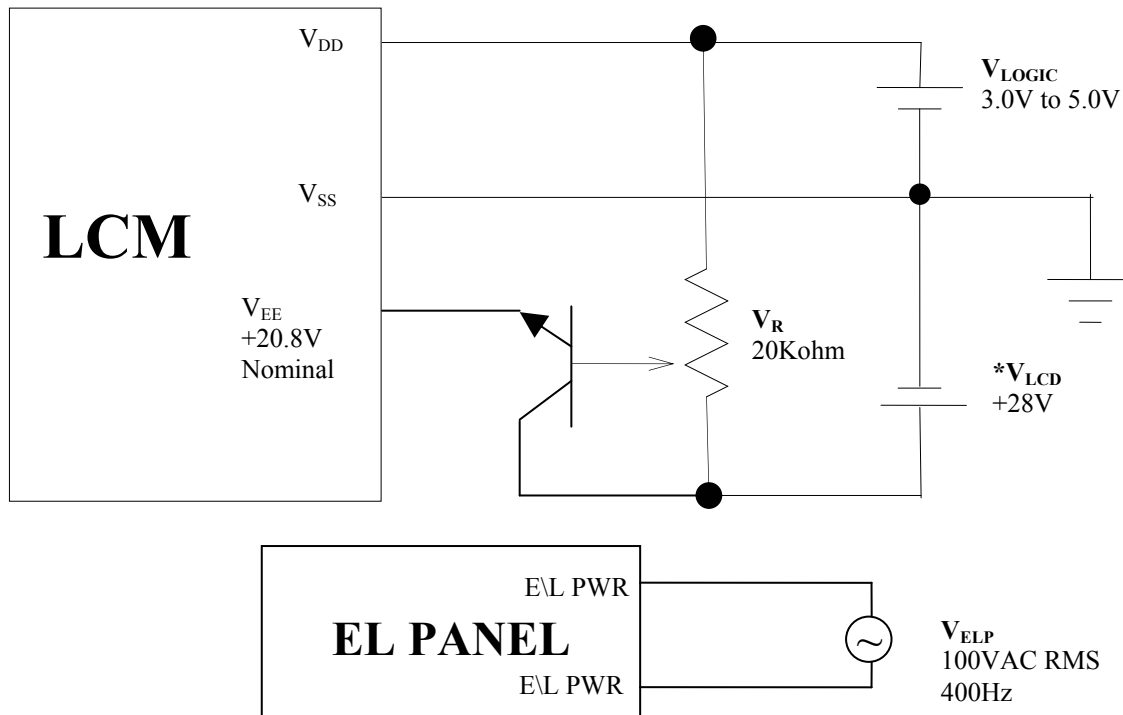

1.8 LCD Dimensions

■ Module Dimensions

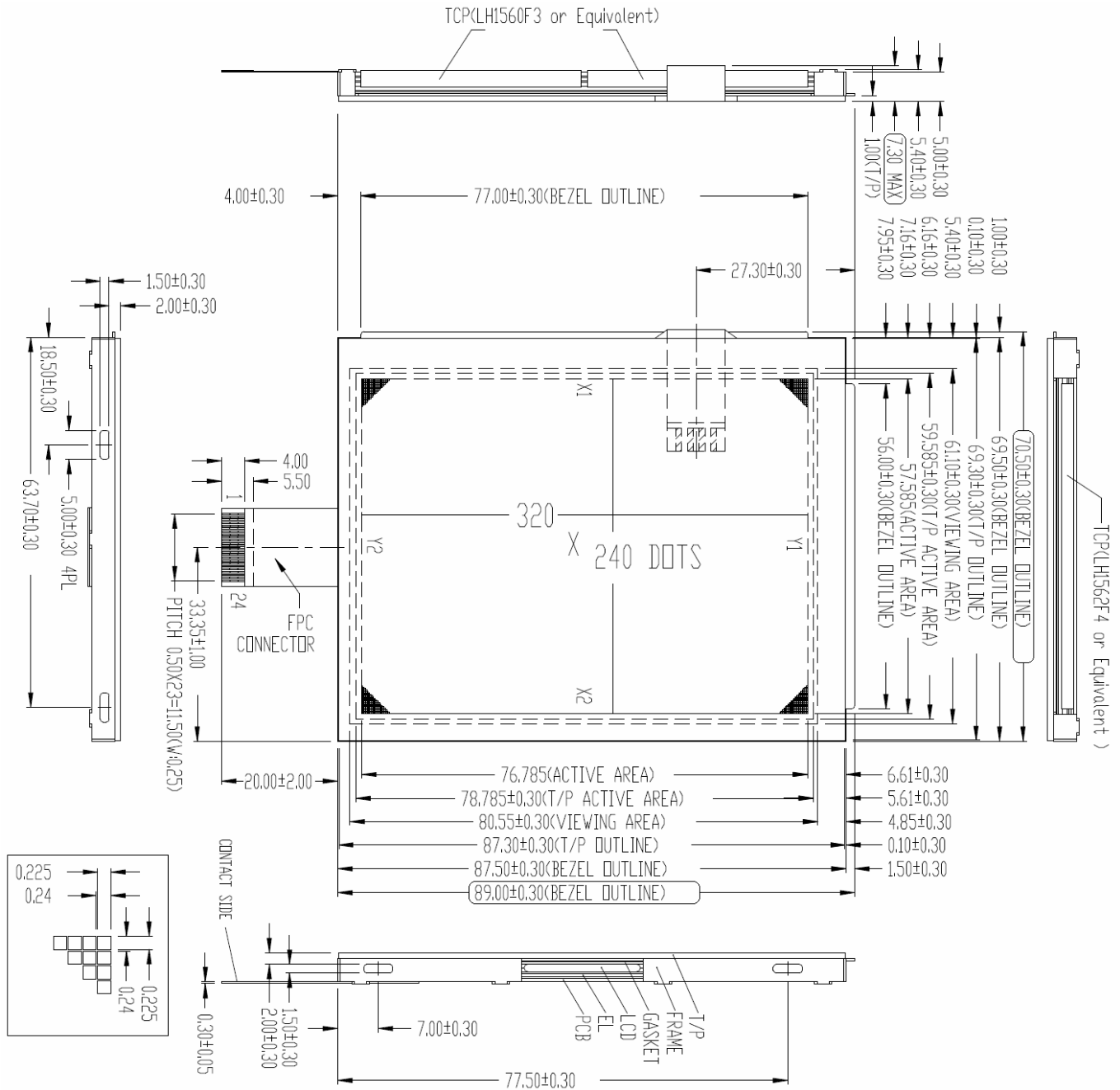

■ FPC Interface Cable Dimensions

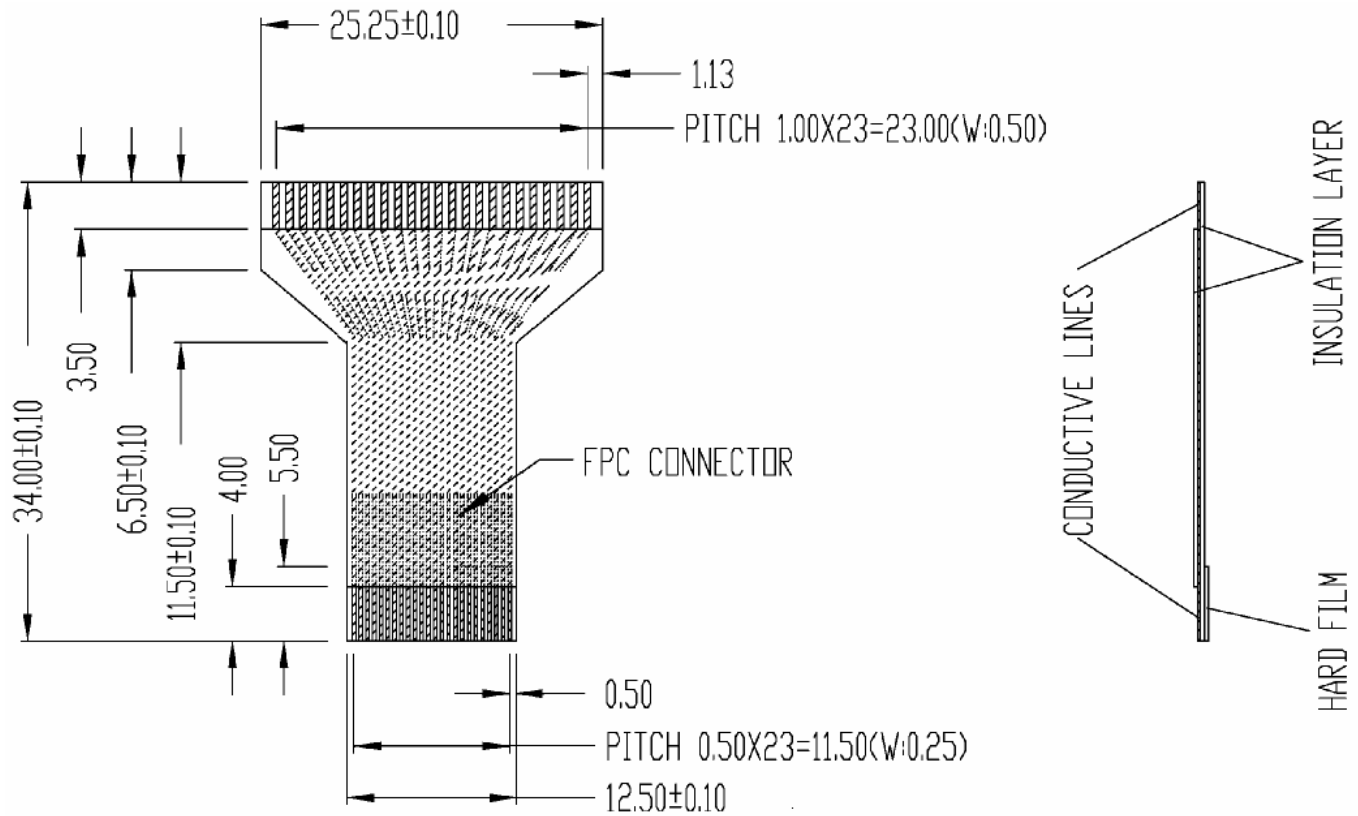

1.8 LCD External Interface Interconnections

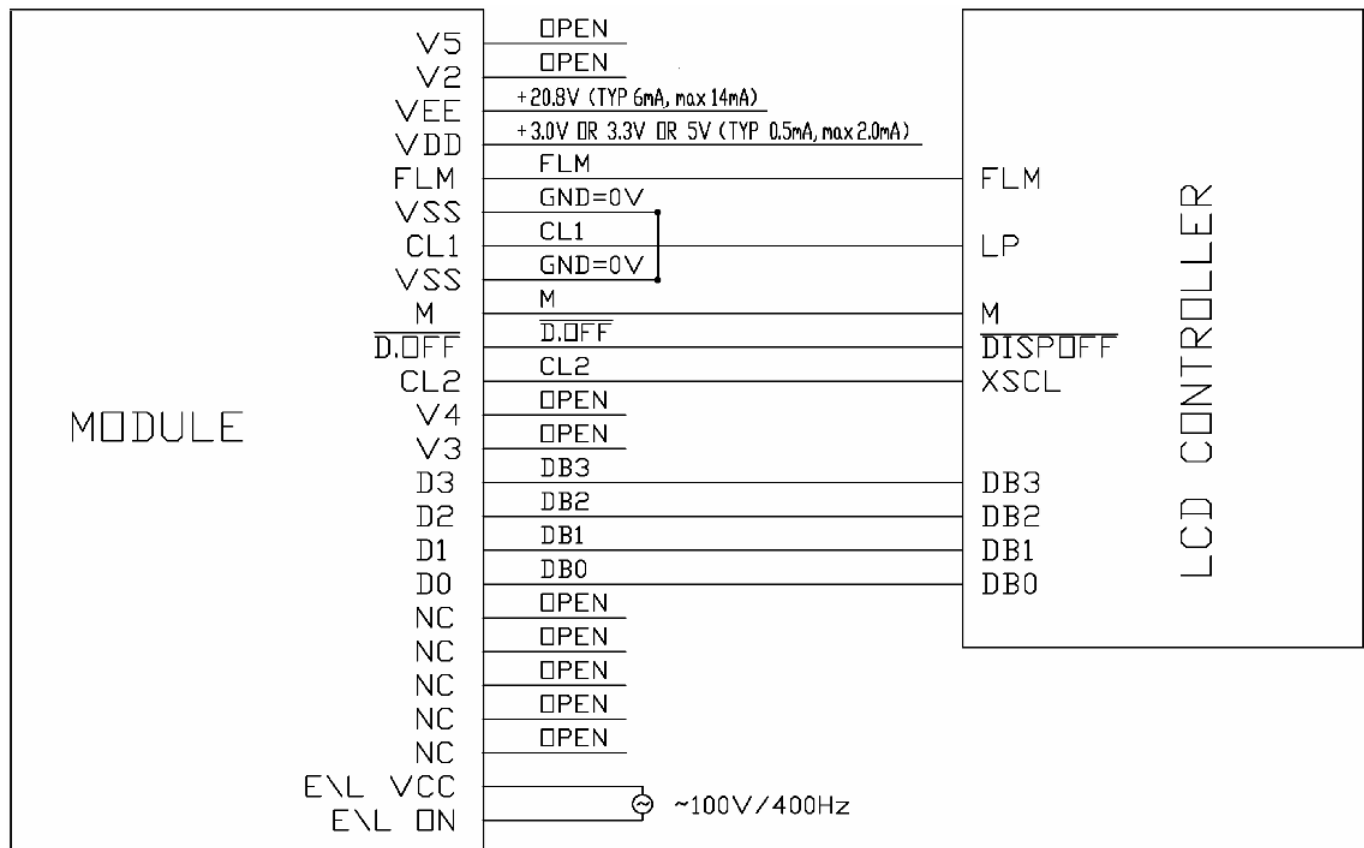

1.9 LCD Module Schematic

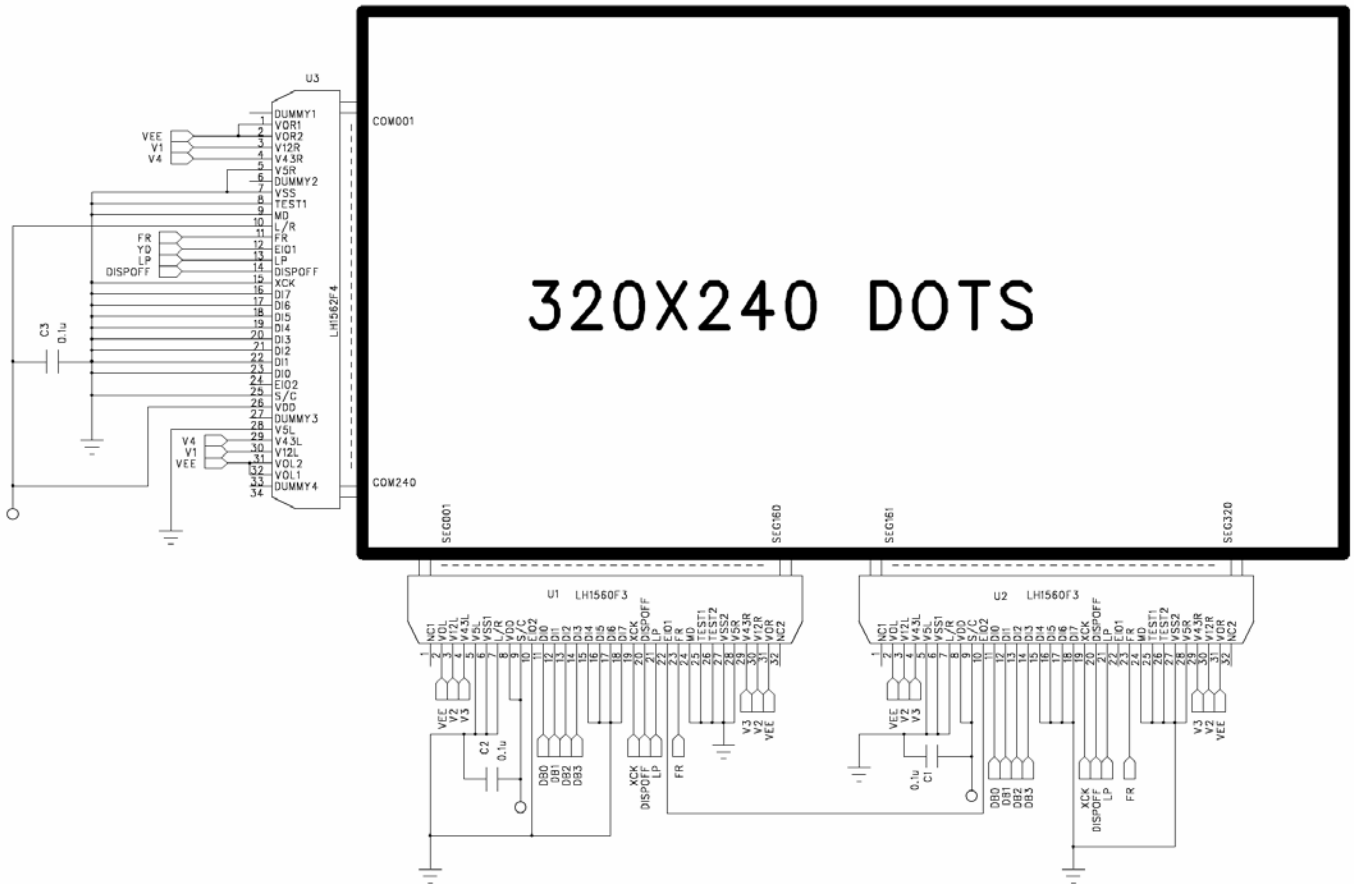
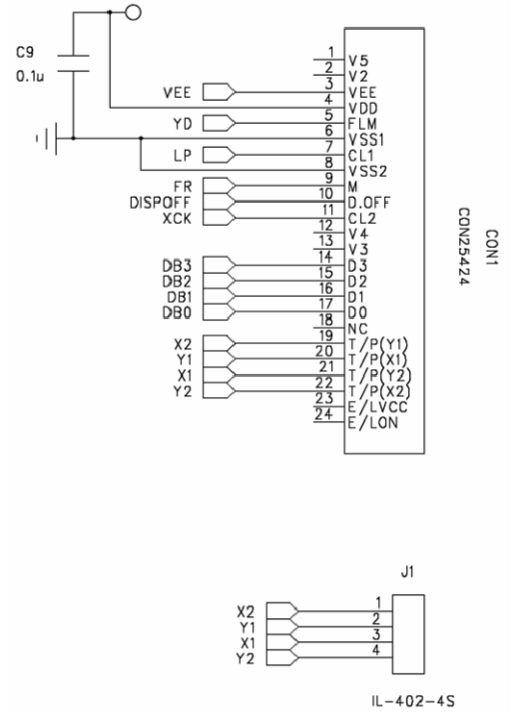
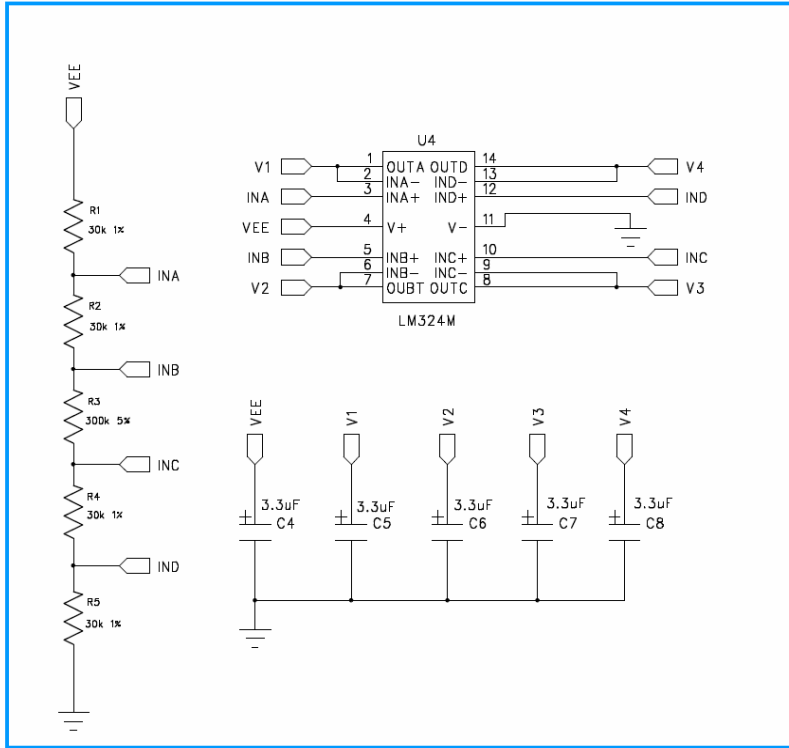

2. ELECTRICAL / OPTICAL CHARACTERISTICS

2.1 DC Electrical Characteristics ($V_{DD} = +5V \pm 10\%$, $V_{SS} = 0V$, $T_a = 25^\circ C$)

Parameter	Symbol	Condition	Min	Typ	Max	Unit
Supply voltage for logic	V_{DD}	---	+2.5	--	+5.5	V
Supply current for logic	I_{DD}	---	---	0.50	2.0	mA
Operating voltage for LCD*	V_{EE} ($V_{EE} - V_{SS}$)	0°C	---	---	---	V
		25°C	+19.6	+20.8	+21.8	V
		50°C	---	---	---	V
Operating current for LCD	I_{EE}	---	---	6.14	14.0	mA
Input voltage 'H' level	V_{IH}	---	0.7 V_{DD}	---	V_{DD}	V
Input voltage 'L' level	V_{IL}	---	0	---	0.3 V_{DD}	V

*NOTE: V_{EE} is a positive voltage, and a negative voltage on V_{EE} will damage the display

2.2 AC Electrical Characteristics

Item	Symbol	Min	Typ	Max	Unit
CL1 pulse width "H"	tW	23	---	---	ns
Clock cycle time	fCP	71	---	---	ns
CL2 pulse width	tWC	23	---	---	ns
Clock set up time	tLSU	25	---	---	ns
Clock hole time	tLC	25	---	---	ns
Clock rise/fall time	tr , tf	---	---	50	ns
Data set up time	tDSU	10	---	---	ns
Data hold time	tDHD	20	---	---	ns
' M ' set up time	tSETUP	25	---	---	ns
' M ' hold time	tHOLD	25	---	---	ns

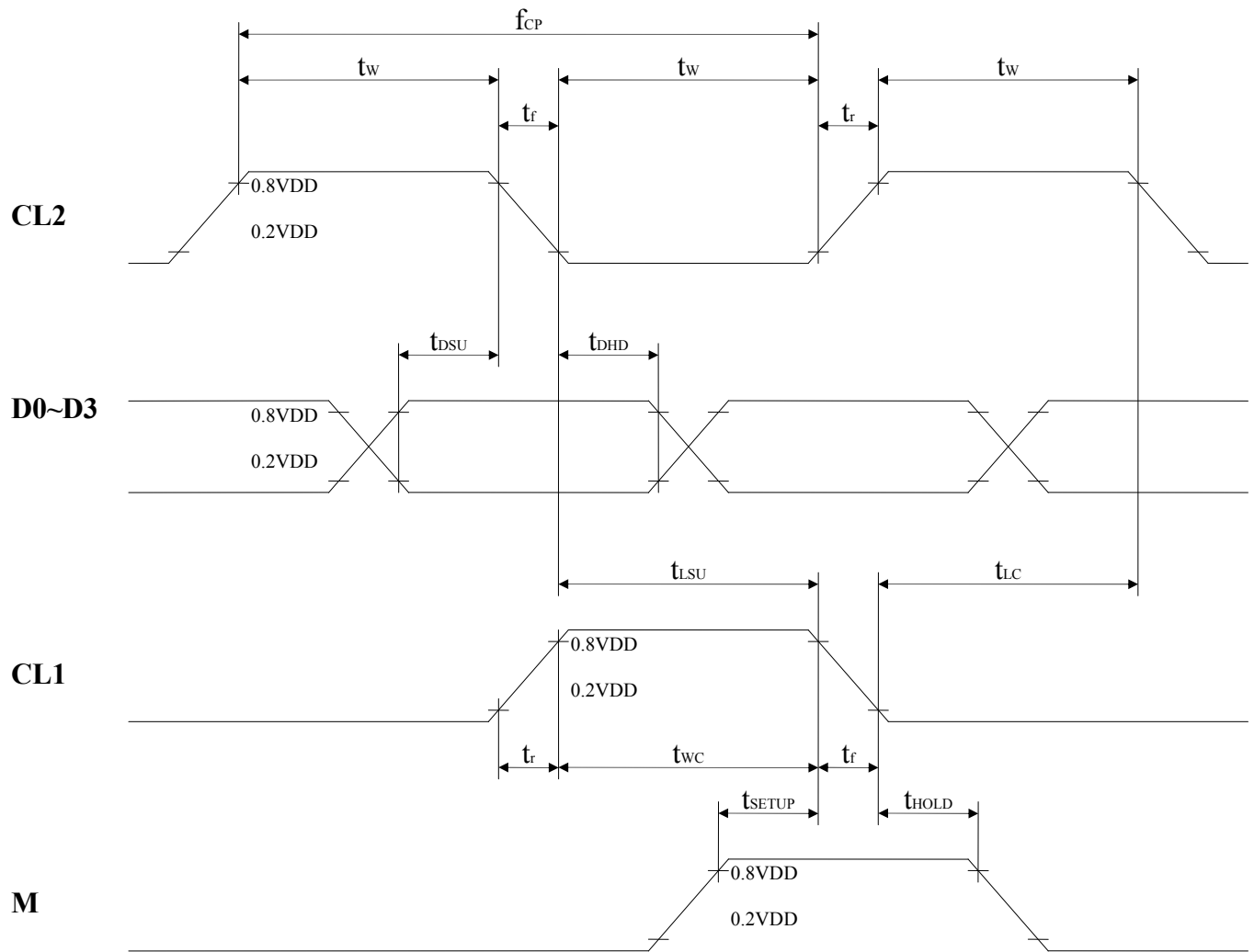

■ TIMING CHART OF INPUT SIGNALS

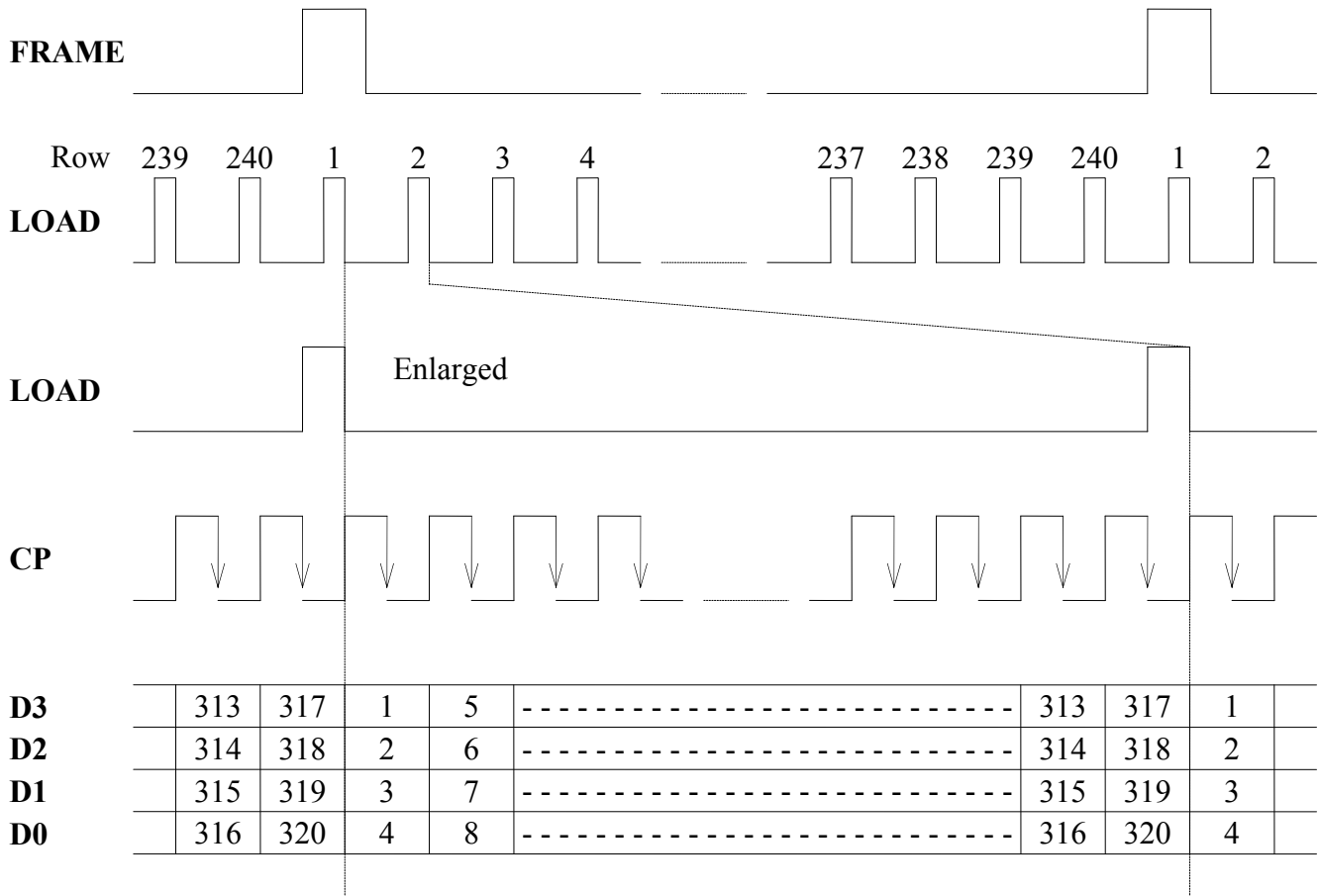

■ DISPLAY DATA PATTERN

	S1	S2	S3	S4	S5	•••••	S316	S317	S318	S319	S320	SEG																																			
C1	D3	D2	D1	D0	D3	•••••	D0	D3	D2	D1	D0																																				
C2	D3	D2	D1	D0	D3	•••••	D0	D3	D2	D1	D0																																				
•	<table border="1"> <thead> <tr> <th>Input data</th> <th colspan="6">Dots on display</th> </tr> </thead> <tbody> <tr> <td>D0</td> <td>Dot 4</td> <td>Dot 8</td> <td>•••</td> <td>Dot 316</td> <td colspan="2">Dot 320</td> </tr> <tr> <td>D1</td> <td>Dot 3</td> <td>Dot 7</td> <td>•••</td> <td>Dot 315</td> <td colspan="2">Dot 319</td> </tr> <tr> <td>D2</td> <td>Dot 2</td> <td>Dot 6</td> <td>•••</td> <td>Dot 314</td> <td colspan="2">Dot 318</td> </tr> <tr> <td>D3</td> <td>Dot 1</td> <td>Dot 5</td> <td>•••</td> <td>Dot 313</td> <td colspan="2">Dot 317</td> </tr> </tbody> </table>												Input data	Dots on display						D0	Dot 4	Dot 8	•••	Dot 316	Dot 320		D1	Dot 3	Dot 7	•••	Dot 315	Dot 319		D2	Dot 2	Dot 6	•••	Dot 314	Dot 318		D3	Dot 1	Dot 5	•••	Dot 313	Dot 317	
Input data													Dots on display																																		
D0													Dot 4	Dot 8	•••	Dot 316	Dot 320																														
D1													Dot 3	Dot 7	•••	Dot 315	Dot 319																														
D2													Dot 2	Dot 6	•••	Dot 314	Dot 318																														
D3													Dot 1	Dot 5	•••	Dot 313	Dot 317																														
C239	D3	D2	D1	D0	D3	•••••	D0	D3	D2	D1	D0																																				
C240	D3	D2	D1	D0	D3	•••••	D0	D3	D2	D1	D0																																				
COM																																															

■ **TIMING OF POWER SUPPLY**

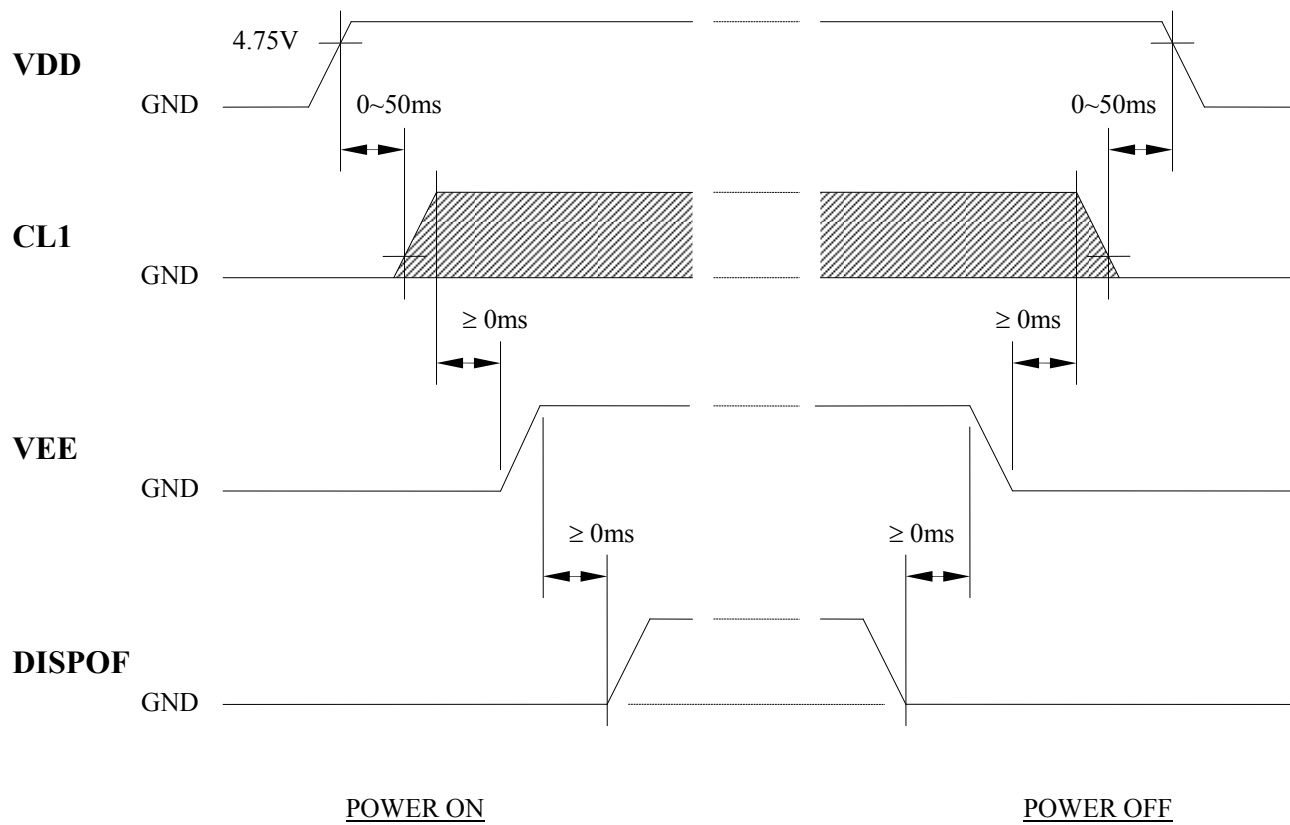

Note : The missing pixels may occur when the LCM is driven except above power supply timing sequence.

2.3 Optical Characteristics (V_{OP} = 4.7V, T_a = 25°C)

Item	Symbol	Condition	Min	Typ	Max	Unit	Remarks	Note
Response time	Tr	---	---	384	---	ms	---	1
	Tf	---	---	220	---	ms	---	1
Contrast ratio	Cr	---	---	6.4	---	---	---	2
Viewing angle range	θ	Cr ≥ 2	20	---	---	deg	∅ = 90°	3
			34	---	---	deg	∅ = 270°	3
			56	---	---	deg	∅ = 0°	3
			33	---	---	deg	∅ = 180°	3

Note 1: Definition of response time.

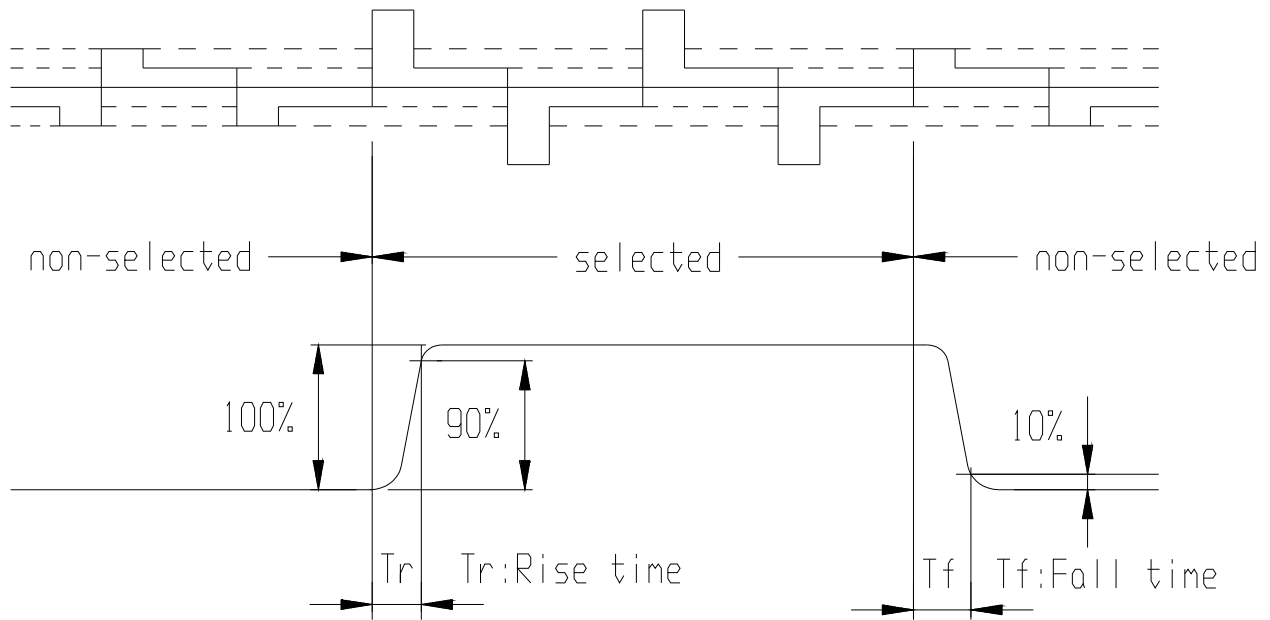

Note2: Definition of contrast ratio 'Cr'

$$Cr = \frac{\text{Brightness of non-selected segment}(B2)}{\text{Brightness of selected segment}(B1)}$$

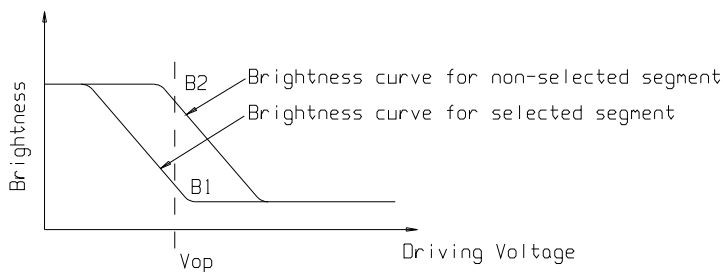

Note3: Definition of viewing angle range 'θ'.

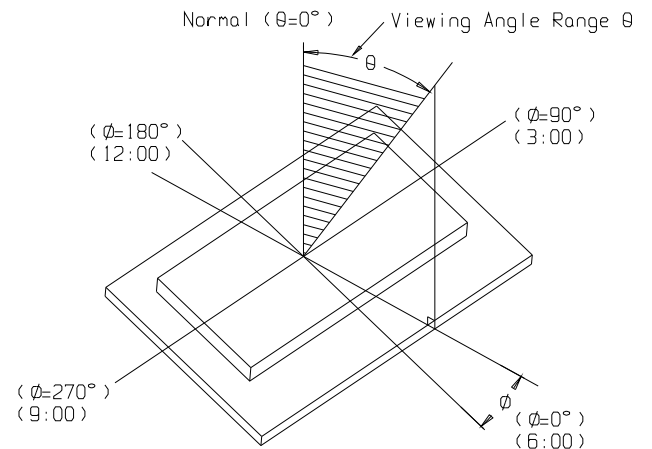

2.4 ELP Backlight Characteristics

■ Blue-Green EL Panel Operating Characteristics:

Item	Conditions	Standard			Unit
		Min.	Typ.	Max.	
Current Consumption	100VAC RMS, 400Hz Ta: 25°C	---	12.0	18.0	mA
EL Drive Voltage	---	---	100	150	VAC RMS
EL Drive Frequency	---	---	400	1000	Hz
Operating Temperature	---	-35°C	---	+50°C	°C
Storage Temperature	---	-40°C	---	+60°C	°C
Luminance	100VAC RMS, 400Hz	40	50	---	cd/m ²
Luminance Half-Life	Ta: 25°C	3500	---	---	Hrs

*Note: half life is defined as Luminance being reduced by 50%

2.5 Optional Touch Panel Characteristics

■ FEATURES

ITEM	FEATURE
Scope	Analog type pen or finger input transparent panels.
Application	The products are Film/Glass type transparent panels used input devices for general electric applications and OA equipment.
Connector	HEAT SEAL

■ OPTICAL DATA

ITEM	Specification
LIGHT TRANSPARENCY	80% TYP.(λ=550nm) in active area
Newton's ring	No remarkable Newton's ring in practical use. Visual inspection shall be done at a distance of 30cm min. between eyes And a product at angles of 60 deg to the surface of the product under a ceiling fluorescent (40W,natural color).

■ MECHANICAL CHARACTERISTICS

ITEM	DATA		NOTE
OPERATION FORCE	PEN	80 g max	Pushed by plastic(R0.8)
	FINGER	80 g max	Pushed by silicon rubber(R8,H=60°)
HARDNESS	2H or over by pencil (JIS K5400, Pressure IN(102GF)45deg.)		
WRITING LIFE	100,000↑words (Min.)		Force by plastic (R0.8),250g
PUNCHING LIFE	1,000,000↑times		Force by silicon rubber(H=60°)200g,2HZ IMPACT E
RESISTANCE	No damage when 9mm steel ball is dropped on the surface from30cm height at 1 time.		

■ ELECTRICAL CHARACTERISTICS

ITEM	DATA		NOTE
RATING	DC 5V		
Terminal Resistance	X-AXIS	350±50Ω TYP	directly measure the data by the Ω meter.
	Y-AXIS	550±50Ω TYP	
LINEALLITY	±1.5%		Refer to 6.1
ON/OFF CHATTING	20 ms		At connector pin
INSULATION RESISTANCE	10 MΩ or over (Dc 25V)		

■ RELIABILITY

ITEM	TEST CONDITION	RESULT
HIGH TEMPERATURE	70°C X 240 Hours	After checked in the each left condition and at normal temperature and humidity for 24hrs. (Except for dew gathering)
LOW TEMPERATURE	-20°C X 240 Hours	
TEMP. & HUMIDITY	60°C X 90%RH x 240 Hours	
THERMAL SHOCK	-10°C X 30 Min 80°C X30 Min. 10 cycles	

4. RELIABILITY

Environmental Test				
No	Test Item	Content of Test	Test Condition	Applicable Standard
1	High temperature storage	Endurance test applying the high storage temperature for a long time.	60 °C 200 hrs	-----
2	Low temperature storage	Endurance test applying the low storage temperature for a long time.	-10 °C 200 hrs	-----
3	High temperature operation	Endurance test applying the electric stress (Voltage & Current) and the thermal stress to the element for a long time.	50 °C 200 hrs	-----
4	Low temperature operation	Endurance test applying the electric stress under low temperature for a long time.	0 °C 200 hrs	-----
5	High temperature / Humidity storage	Endurance test applying the high temperature and high humidity storage for a long time.	60 °C , 90 %RH 96 hrs	MIL-202E-103B JIS-C5023
6	High temperature / Humidity operation	Endurance test applying the electric stress (Voltage & Current) and temperature / humidity stress to the element for a long time.	40 °C , 90 %RH 96 hrs	MIL-202E-103B JIS-C5023
7	Temperature cycle	Endurance test applying the low and high temperature cycle. $\begin{matrix} & - & \rightleftharpoons & 25^{\circ}\text{C} & \rightleftharpoons & 70^{\circ}\text{C} \\ \leftarrow & 20^{\circ}\text{C} & \rightleftharpoons & 5\text{min} & \rightleftharpoons & 30\text{mj} \\ & & & 1 & & \end{matrix}$	-10°C / 60°C 10 cycles	-----
Mechanical Test				
8	Vibration test	Endurance test applying the vibration during transportation and using.	10~22Hz → 1.5mmp-p 22~500Hz → 1.5G Total 0.5hrs	MIL-202E-201A JIS-C5025 JIS-C7022-A-10
9	Shock test	Constructional and mechanical endurance test applying the shock during transportation.	50G Half sign wave 11 msec 3 times of each direction	MIL-202E-213B
10	Atmospheric pressure test	Endurance test applying the atmospheric pressure during transportation by air.	115 mbar 40 hrs	MIL-202E-105C
Others				
11	Static electricity test	Endurance test applying the electric stress to the terminal.	VS=800V , RS=1.5 kΩ CS=100 pF 1 time	MIL-883B-3015.1

*** Supply voltage for logic system = VDD. Supply voltage for LCD system = Operating voltage at 25°C

■ LCD Panel Service Life

Definition of panel service life

- 100,000 hours minimum at 25° C ±10%
- Contrast becomes 30% of initial value
- Current consumption becomes three times higher than initial value
- Remarkable alignment deterioration occurs in LCD cell layer
- Unusual operation occurs in display functions

5. PRECAUTIONS FOR USING LCD MODULES

Installing LCD Modules

The hole in the printed circuit board is used to fix LCM as shown in the picture below. Attend to the following items when installing the LCM.

- 1) Cover the surface with a transparent protective plate to protect the polarizer and LC cell.

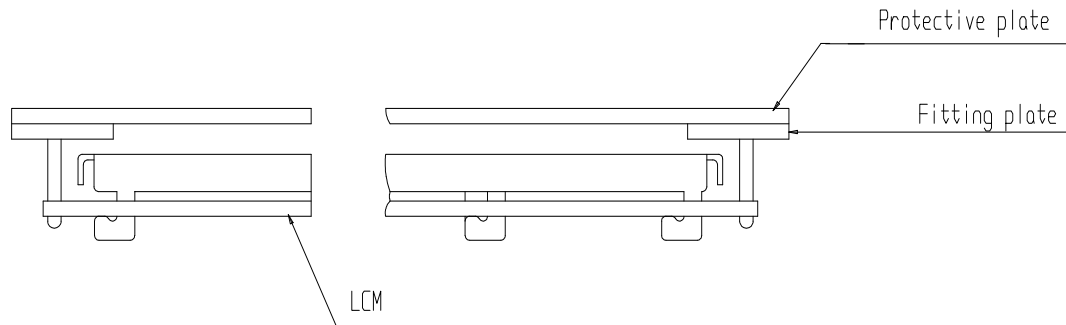

- 2) When assembling the LCM into other equipment, the spacer to the bit between the LCM and the fitting plate should have enough height to avoid causing stress to the module surface, refer to the individual specifications for measurements. The measurement tolerance should be ± 0.1 mm.

Precaution for Handling LCD Modules

Since LCM has been assembled and adjusted with a high degree of precision, avoid applying excessive shocks to the module or making any alterations or modifications to it.

- 1) Cover the surface with a transparent protective plate to protect the polarizer and LC cell.
- 2) Do not alter, modify or change the shape of the tab on the metal frame.
- 3) Do not make extra holes on the printed circuit board, modify its shape or change the positions of components to be attached.
- 4) Do not damage or modify the pattern writing on the printed circuit board.
- 5) Absolutely do not modify the zebra rubber strip (conductive rubber) or heat seal connector.
- 6) Except for soldering the interface, do not make any alterations or modifications with a soldering iron.
- 7) Do not drop, bend or twist LCM.

Electro-Static Discharge Control

Since this module uses a CMOS LSI, the same careful attention should be paid to electrostatic discharge as for an ordinary CMOS IC.

- 1) Make certain that you are grounded when handling LCM.
- 2) Before remove LCM from its packing case or incorporating it into a set, be sure the module and your body have the same electric potential.
- 3) When soldering the terminal of LCM, make certain the AC power source for the soldering iron does not leak.
- 4) When using an electric screwdriver to attach LCM, the screwdriver should be of ground potentiality to minimize as much as possible any transmission of electromagnetic waves produced sparks coming from the commutator of the motor.
- 5) As far as possible make the electric potential of your work clothes and that of the work bench the ground potential.
- 6) To reduce the generation of static electricity be careful that the air in the work is not too dried. A relative humidity of 50%-60% is recommended.

Precaution for soldering to the LCM

- 1) Observe the following when soldering lead wire, connector cable and etc. to the LCM.
 - a) Soldering iron temperature : $280^{\circ}\text{C} \pm 10^{\circ}\text{C}$.
 - b) Soldering time : 3-4 sec.
- 2) Solder : eutectic solder.

- 3) If soldering flux is used, be sure to remove any remaining flux after finishing to soldering operation. (This does not apply in the case of a non-halogen type of flux.) It is recommended that you protect the LCD surface with a cover during soldering to prevent any damage due to flux spatters.
- 4) When soldering the electroluminescent panel and PC board, the panel and board should not be detached more than three times. This maximum number is determined by the temperature and time conditions mentioned above, though there may be some variance depending on the temperature of the soldering iron.
- 5) When remove the electroluminescent panel from the PC board, be sure the solder has completely melted, the soldered pad on the PC board could be damaged.

Precautions for Operation

- 1) Viewing angle varies with the change of liquid crystal driving voltage (VO). Adjust VO to show the best contrast.
- 2) Driving the LCD in the voltage above the limit shortens its life.
- 3) Response time is greatly delayed at temperature below the operating temperature range. However, this does not mean the LCD will be out of the order. It will recover when it returns to the specified temperature range.
- 4) If the display area is pushed hard during operation, the display will become abnormal. However, it will return to normal if it is turned off and then back on.
- 5) Condensation on terminals can cause an electrochemical reaction disrupting the terminal circuit. Therefore, it must be used under the relative condition of 40°C , 50% RH.
- 6) When turning the power on, input each signal after the positive/negative voltage becomes stable.

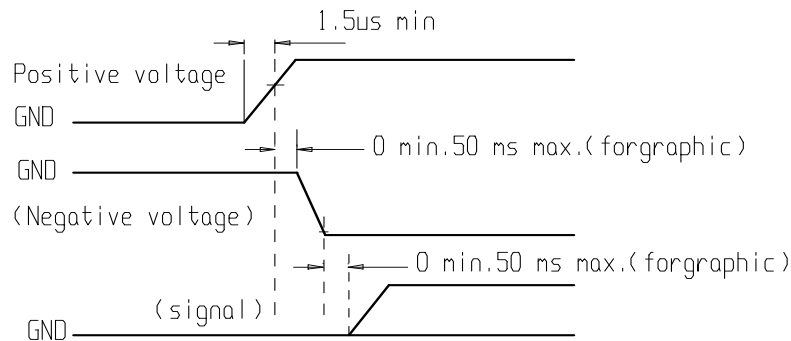

Safety

- If the LCD panel breaks, be careful not to get the liquid crystal in your mouth. If the liquid crystal touches your skin or clothes, wash it off immediately using soap and plenty of water.

Handling

- The display panel is made of glass. Do not subject it to a mechanical shock by dropping it or impact.
- If the display panel is damaged and the liquid crystal substance leaks out, be sure not to get any in your mouth. If the substance contacts your skin or clothes, wash it off using soap and water.
- Do not apply excessive force to the display surface or the adjoining areas since this may cause the color tone to vary.
- The polarizer covering the display surface of the LCD module is soft and easily scratched. Handle this polarizer carefully.
- If the display surface becomes contaminated, breathe on the surface and gently wipe it with a soft dry cloth. If it is heavily contaminated, moisten cloth with one of the following solvents :
 - Isopropyl alcohol
 - Ethyl alcohol
- Solvents other than those above-mentioned may damage the polarizer. Especially, do not use the following.
 - Water
 - Ketone
 - Aromatic solvents
- Exercise care to minimize corrosion of the electrode. Corrosion of the electrodes is accelerated by water droplets, moisture condensation or a current flow in a high-humidity environment.
- Install the LCD Module by using the mounting holes. When mounting the LCD module make sure it is free of twisting, warping and distortion. In particular, do not forcibly pull or bend the I/O cable or the backlight cable.
- Do not attempt to disassemble or process the LCD module.
- NC terminal should be open. Do not connect anything.
- If the logic circuit power is off, do not apply the input signals.

- To prevent destruction of the elements by static electricity, be careful to maintain an optimum work environment.
 - Be sure to ground the body when handling the LCD modules.
 - Tools required for assembling, such as soldering irons, must be properly grounded.
 - To reduce the amount of static electricity generated, do not conduct assembling and other work under dry conditions.
 - The LCD module is coated with a film to protect the display surface. Exercise care when peeling off this protective film since static electricity may be generated.

Storage

- When storing the LCD modules, avoid exposure to direct sunlight or to the light of fluorescent lamps
- Store the module in a dark place where the temperature is $25^{\circ}\text{C} \pm 10^{\circ}\text{C}$ and the humidity below 65% RH.
- Do not store the module near organic solvents or corrosive gases.
- Do not crush, shake, or jolt the module (including accessories).

Cleaning

- Do not wipe the polarizing plate with a dry cloth, as it may scratch the surface.
- Wipe the module gently with soft cloth soaked with a petroleum benzene.
- Do not use ketonic solvents (ketone and acetone) or aromatic solvents (toluene and xylene), as they may damage the polarizing plate.

Others:

- Liquid crystals solidify under low temperature (below the storage temperature range) leading to defective orientation or the generation of air bubbles (black or white). Air bubbles may also be generated if the module is subject to a low temperature.
- If the LCD modules have been operating for a long time showing the same display patterns, the display patterns may remain on the screen as ghost images and a slight contrast irregularity may also appear. A normal operating status can be regained by suspending use for some time. It should be noted that this phenomenon does not adversely affect performance reliability.
- To minimize the performance degradation of the LCD modules resulting from destruction caused by static electricity etc., exercise care to avoid holding the following sections when handling the modules.
 - Exposed area of the printed circuit board.
 - Terminal electrode sections.