

Technical Document

- [FAQs](#)
- [Application Note](#)

Features

- Operating voltage: 2.7V~5.2V
- Built-in 32kHz RC oscillator
- External 32.768kHz crystal oscillator or 32kHz frequency source input
- Standby current: <1μA at 3V, <2μA at 5V
- Internal resistor type: 1/6 bias or 1/5 bias, 1/32 duty, or 1/16 duty
- Three selectable LCD frame frequencies: 64Hz, 89Hz or 170Hz
- Max. 96×32 patterns, 96 segments and 32 commons
- 112 segments and 16 commons selectable by command method
- Built-in bit-map display RAM: 3072 bits (=96×32 bits)
- Built-in internal resistor type bias generator
- Six-wire interface (four data wires)
- Eight kinds of time base/WDT selection
- Time base or WDT overflow output
- R/W address auto increment
- Built-in buzzer driver (2kHz/4kHz)
- Power down command reduces power consumption
- Software configuration feature
- Data mode and Command mode instructions
- Three data accessing modes
- Provides VLCD pin to adjust LCD operating voltage and max. VLCD voltage up to 7V
- Provides three kinds of bias current programming
- Control of TN-type and STN-type LCDs
- 160-pin QFP package

Applications

- Leisure products
- Games
- Personal digital assistant
- Cellular phone
- Global positioning system
- Consumer electronics

General Description

HT1660 is a peripheral device specially designed for I/O type MCU used to expand the display capability. The max. display segment of the device are 3072 patterns (96 segments and 32 commons). It also supports four data bits interface, buzzer sound, Watchdog Timer or time base timer functions. The HT1660 is a memory mapping and multi-function LCD controller. Since the

HT1660 can control TN-type (Twisted Nematic) or STN-type (Super Twisted Nematic) LCDs. The software configuration feature of the HT1660 make it suitable for multiple LCD applications including LCD modules and display subsystems. Only six lines (\overline{CS} , \overline{WR} , DB0~DB3) are required for the interface between the host controller and the HT1660.

Block Diagram

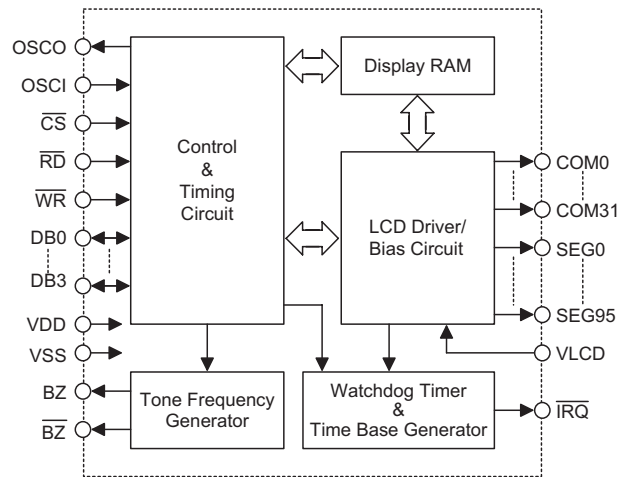

Note: \overline{CS} : Chip selection
 \overline{BZ} , \overline{BZ} : Tone outputs
 \overline{WR} , \overline{RD} : WRITE clock, READ clock
 $\overline{DB0}$ - $\overline{DB3}$: Data bus
 $\overline{COM0}$ - $\overline{COM31}$, $\overline{SEG0}$ - $\overline{SEG95}$: LCD outputs
 \overline{IRQ} : Time base or WDT overflow output

Pin Assignment

COM19	1	161	SEG67	120
COM18	2	151	SEG66	119
COM17	3	141	SEG65	118
COM16	4	131	SEG64	117
NC	5	121	SEG63	116
NC	6	111	SEG62	115
NC	7	101	SEG61	114
NC	8	91	SEG60	113
NC	9	81	SEG59	112
NC	10	71	SEG58	111
\overline{CS}	11	61	SEG57	110
\overline{RD}	12	51	SEG56	109
\overline{WR}	13	41	SEG55	108
$\overline{DB0}$	14	31	SEG54	107
$\overline{DB1}$	15	21	SEG53	106
$\overline{DB2}$	16	11	SEG52	105
$\overline{DB3}$	17	01	SEG51	104
VSS	18		SEG50	103
OSCI	19		SEG49	102
OSCO	20		SEG48	101
VDD	21		SEG47	100
VLCD	22		SEG46	99
\overline{IRQ}	23		SEG45	98
\overline{BZ}	24		SEG44	97
\overline{BZ}	25		SEG43	96
T1	26		SEG42	95
T2	27		SEG41	94
T3	28		SEG40	93
T4	29		SEG39	92
T000	30		SEG38	91
VLCD	31		SEG37	90
NC	32		SEG36	89
NC	33		SEG35	88
NC	34		SEG34	87
NC	35		SEG33	86
NC	36		SEG32	85
COM0	37		SEG31	84
COM1	38		SEG30	83
COM2	39		SEG29	82
COM3	40		SEG28	81

HT1660
-160 QFP-A

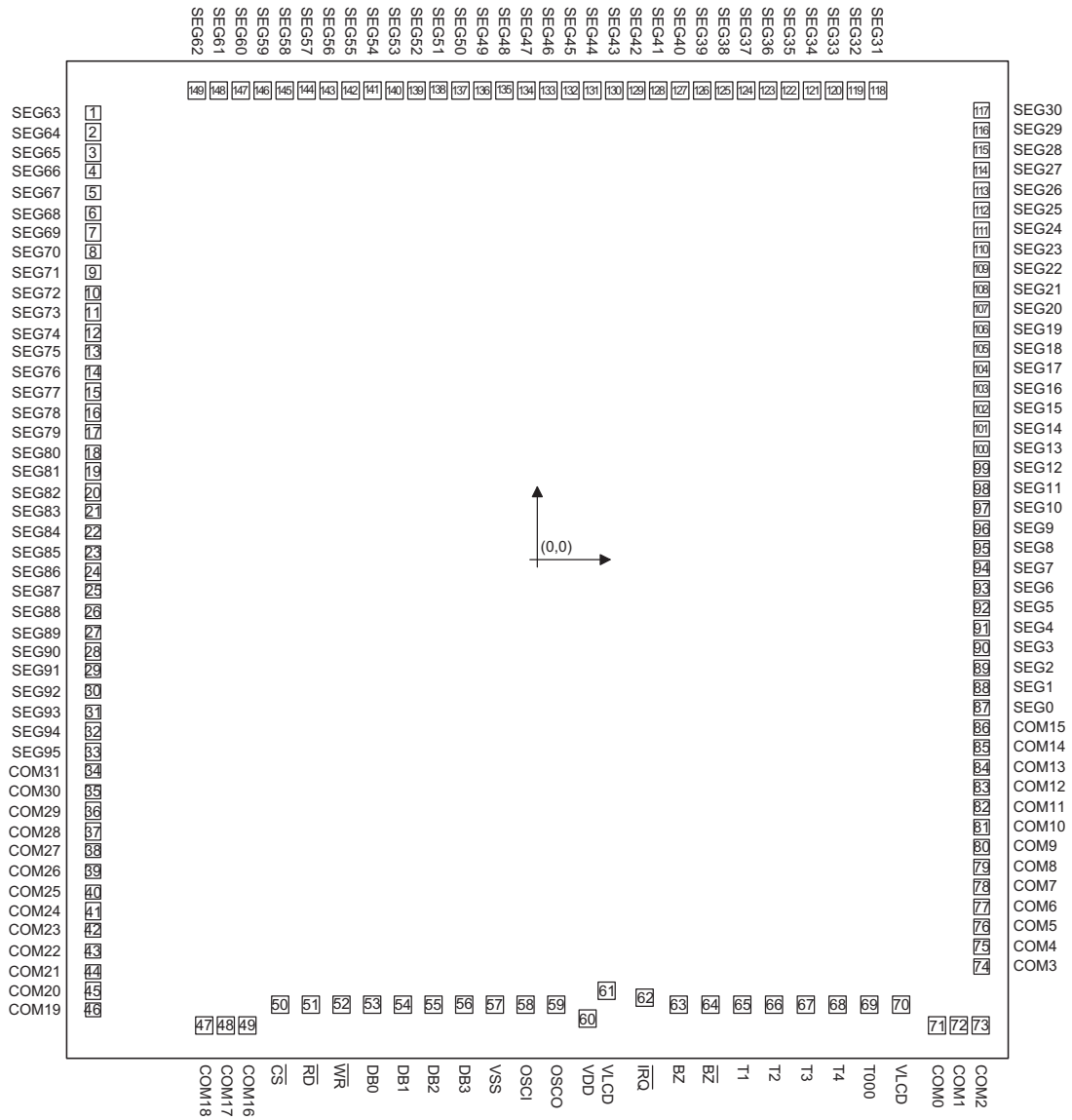
Pad Assignment

Chip size: 4340x5030 (μm)²

* The IC substrate should be connected to VSS in the PCB layout artwork.

Pad Coordinates

 Unit: μm

Pad No.	X	Y	Pad No.	X	Y	Pad No.	X	Y
1	-2028.50	2237.20	51	-1027.85	-2225.20	101	2028.45	654.20
2	-2028.50	2137.20	52	-892.45	-2225.20	102	2028.45	754.20
3	-2028.50	2037.20	53	-745.55	-2225.20	103	2028.45	854.20
4	-2028.50	1937.20	54	-610.15	-2225.20	104	2028.45	954.20
5	-2028.50	1837.20	55	-464.85	-2225.20	105	2028.45	1054.20
6	-2028.50	1637.20	56	-329.25	-2225.20	106	2028.45	1154.20
7	-2028.50	1537.20	57	-187.15	-2225.30	107	2028.45	1254.20
8	-2028.50	1437.20	58	-53.65	-2229.70	108	2028.45	1354.20
9	-2028.50	1337.20	59	84.55	-2229.70	109	2028.45	1454.20
10	-2028.50	1237.20	60	222.85	-2297.35	110	2028.45	1554.20
11	-2028.50	1237.20	61	310.40	-2162.35	111	2028.45	1654.20
12	-2028.50	1137.20	62	492.00	-2183.60	112	2028.45	1754.20
13	-2028.50	1037.20	63	638.50	-2225.30	113	2028.45	1854.20
14	-2028.50	937.20	64	773.90	-2225.30	114	2028.45	1954.20
15	-2028.50	837.20	65	933.50	-2225.30	115	2028.45	2054.20
16	-2028.50	737.20	66	1081.70	-2225.30	116	2028.45	2154.20
17	-2028.50	637.20	67	1228.70	-2225.30	117	2028.45	2254.20
18	-2028.50	537.20	68	1376.90	-2225.30	118	1550.75	2349.60
19	-2028.50	437.20	69	1523.90	-2225.30	119	1450.75	2349.60
20	-2028.50	337.20	70	1662.50	-2225.30	120	1350.75	2349.60
21	-2028.50	237.20	71	1821.19	-2338.90	121	1250.75	2349.60
22	-2028.50	137.20	72	1921.19	-2338.90	122	1150.75	2349.60
23	-2028.50	37.20	73	2021.19	-2338.90	123	1050.75	2349.60
24	-2028.50	-62.80	74	2028.45	-2051.10	124	950.75	2349.60
25	-2028.50	-162.80	75	2028.45	-1951.10	125	850.75	2349.60
26	-2028.50	-262.80	76	2028.45	-1851.10	126	750.75	2349.60
27	-2028.50	-362.80	77	2028.45	-1751.10	127	650.75	2349.60
28	-2028.50	-462.80	78	2028.45	-1651.10	128	550.75	2349.60
29	-2028.50	-562.80	79	2028.45	-1551.10	129	450.75	2349.60
30	-2028.50	-662.80	80	2028.45	-1451.10	130	350.75	2349.60
31	-2028.50	-762.80	81	2028.45	-1351.10	131	250.75	2349.60
32	-2028.50	-862.80	82	2028.45	-1251.10	132	150.75	2349.60
33	-2028.50	-962.80	83	2028.45	-1151.10	133	50.75	2349.60
34	-2028.50	-1062.80	84	2028.45	-1051.10	134	-49.25	2349.60
35	-2028.50	-1162.80	85	2028.45	-951.10	135	-149.25	2349.60
36	-2028.50	-1262.80	86	2028.45	-851.10	136	-249.25	2349.60
37	-2028.50	-1362.80	87	2028.45	-745.80	137	-349.25	2349.60
38	-2028.50V	-1462.80	88	2028.45	-645.80	138	-449.25	2349.60
39	-2028.50	-1562.80	89	2028.45	-545.80	139	-549.25	2349.60
40	-2028.50	-1662.80	90	2028.45	-445.80	140	-649.25	2349.60
41	-2028.50	-1762.80	91	2028.45	-345.80	141	-749.25	2349.60
42	-2028.50	-1862.80	92	2028.45	-245.80	142	-849.25	2349.60
43	-2028.50	-1962.80	93	2028.45	-145.80	143	-949.25	2349.60
44	-2028.50	-2062.80	94	2028.45	-45.80	144	-1049.25	2349.60
45	-2028.50	-2162.80	95	2028.45	54.20	145	-1149.25	2349.60
46	-2028.50	-2262.80	96	2028.45	154.20	146	-1249.25	2349.60
47	-1523.55	-2337.10	97	2028.45	254.20	147	-1349.25	2349.60
48	-1423.55	-2337.10	98	2028.45	354.20	148	-1449.25	2349.60
49	-1323.55	-2337.10	99	2028.45	454.20	149	-1549.25	2349.60
50	-1170.45	-2225.20	100	2028.45	554.20			

Pad Description

Pad No.	Pad Name	I/O	Description
1~33 87~149	SEG63~SEG95 SEG0~SEG62	O	LCD segment outputs
34~49 71~86	COM31~COM16 COM0~COM15	O	LCD common outputs, under 112×16 command mode, COM16~COM31 will share to SEG96~SEG111. COM31/SEG96, COM30/SEG97, COM29/SEG98....., COM18/SEG109, COM17/SEG110, COM16/SEG111
50	\overline{CS}	I	Chip selection input with pull-high resistor. When the \overline{CS} is logic high, the data and command read from or write to the HT1660 are disabled. The serial interface circuit is also reset. But if the \overline{CS} is at a logic low level and is input to the \overline{CS} pad, the data and command transmission between the host controller and the HT1660 are all enabled.
51	\overline{RD}	I	READ clock input with pull-high resistor. Data in the RAM of the HT1660 are clocked out on the falling edge of the \overline{RD} signal. The clocked out data will appear on the data line. The host controller can use the next rising edge to latch the clocked out data.
52	\overline{WR}	I	WRITE clock input with pull-high resistor. Data on the DATA line are latched into the HT1660 on the rising edge of the \overline{WR} signal.
53~56	DB0~DB3	I/O	Parallel data input/output with a pull-high resistor
57	VSS	—	Negative power supply for logic circuit, ground
58 59	OSCI OSCO	I O	The OSCI and OSCO pads are connected to a 32.768kHz crystal in order to generate a system clock. If the system clock comes from an external clock source, the external clock source should be connected to the OSCI pad. But if an on-chip RC oscillator is selected, the OSCI and OSCO pads can be left open.
60	VDD	—	Positive power supply for logic circuit
61	VLCD	I	Power supply for LCD driver circuit
62	\overline{IRQ}	O	Time base or Watchdog Timer overflow flag, NMOS open drain output.
63, 64	BZ, \overline{BZ}	O	2kHz or 4kHz frequency output pair (tristate output buffer)
65~69	T1~T4, T000	I	Vary bias current pin It is usually not connected

Absolute Maximum Ratings

Supply Voltage $V_{SS}-0.3V$ to $V_{SS}+5.5V$ Storage Temperature $-50^{\circ}C$ to $125^{\circ}C$
 Input Voltage $V_{SS}-0.3V$ to $V_{DD}+0.3V$ Operating Temperature $-25^{\circ}C$ to $75^{\circ}C$

Note: These are stress ratings only. Stresses exceeding the range specified under "Absolute Maximum Ratings" may cause substantial damage to the device. Functional operation of this device at other conditions beyond those listed in the specification is not implied and prolonged exposure to extreme conditions may affect device reliability.

D.C. Characteristics

Ta=25°C

Symbol	Parameter	Test Conditions		Min.	Typ.	Max.	Unit
		V _{DD}	Conditions				
V _{DD}	Operating Voltage	—	—	2.7	—	5.2	V
I _{DD1}	Operating Current	3V	No load/LCD ON	—	150	250	μA
		5V	On-chip RC oscillator	—	250	370	μA
I _{DD2}	Operating Current	3V	No load/LCD ON	—	135	200	μA
		5V	Crystal oscillator	—	200	300	μA
I _{DD11}	Operating Current	3V	No load/LCD OFF	—	15	30	μA
		5V	On-chip RC oscillator	—	50	70	μA
I _{DD22}	Operating Current	3V	No load/LCD OFF	—	2	10	μA
		5V	Crystal oscillator	—	3	10	μA
I _{STB}	Standby Current	3V	No load, Power down mode	—	—	1	μA
		5V		—	—	2	μA
V _{IL}	Input Low Voltage	3V	DB0~DB3, \overline{WR} , \overline{CS} , \overline{RD}	0	—	0.6	V
		5V		0	—	1.0	V
V _{IH}	Input High Voltage	3V	DB0~DB3, \overline{WR} , \overline{CS} , \overline{RD}	2.4	—	3	V
		5V		4.0	—	5	V
I _{OL1}	BZ, \overline{BZ} , \overline{IRQ} Sink Current	3V	V _{OL} =0.3V	1.2	2.5	—	mA
		5V	V _{OL} =0.5V	3	6	—	mA
I _{OH1}	BZ, \overline{BZ} Source Current	3V	V _{OH} =2.7V	-0.9	-1.8	—	mA
		5V	V _{OH} =4.5V	-2	-4	—	mA
I _{OL2}	DB0~DB3 Sink Current	3V	V _{OL} =0.3V	1.2	2.5	—	mA
		5V	V _{OL} =0.5V	3	6	—	mA
I _{OH2}	DB0~DB3 Source Current	3V	V _{OH} =2.7V	-0.9	-1.8	—	mA
		5V	V _{OH} =4.5V	-2	-4	—	mA
I _{OL3}	LCD Common Sink Current	3V	V _{OL} =0.3V	80	160	—	μA
		5V	V _{OL} =0.5V	180	360	—	μA
I _{OH3}	LCD Common Source Current	3V	V _{OH} =2.7V	-40	-80	—	μA
		5V	V _{OH} =4.5V	-90	-180	—	μA
I _{OL4}	LCD Segment Sink Current	3V	V _{OL} =0.3V	50	100	—	μA
		5V	V _{OL} =0.5V	120	240	—	μA
I _{OH4}	LCD Segment Source Current	3V	V _{OH} =2.7V	-30	-60	—	μA
		5V	V _{OH} =4.5V	-70	-140	—	μA
R _{PH}	Pull-high Resistor	3V	DB0~DB3, \overline{WR} , \overline{CS} , \overline{RD}	150	250	410	kΩ
		5V		60	125	210	kΩ

A.C. Characteristics

Ta=25°C

Symbol	Parameter	Test Conditions		Min.	Typ.	Max.	Unit
		V _{DD}	Conditions				
f _{SYS1}	System Clock	3V	On-chip RC oscillator	22	32	40	kHz
		5V		24	32	40	
f _{SYS2}	System Clock	3V	Crystal oscillator	—	32.768	—	kHz
		5V		—	32.768	—	
f _{SYS3}	System Clock	3V	External clock source	—	32	—	kHz
		5V		—	32	—	
f _{LCD1}	LCD Frame Frequency	3V	On-chip RC oscillator	61/117	89/170	111/213	Hz
		5V		61/117	89/170	111/213	
f _{LCD2}	LCD Frame Frequency	3V	Crystal oscillator	—	64	—	Hz
		5V		—	64	—	
f _{LCD3}	LCD Frame Frequency	3V	External clock source	—	64	—	Hz
		5V		—	64	—	
t _{COM}	LCD Common Period	—	n: Number of COM	—	n/f _{LCD}	—	sec
f _{CLK1}	4-Bit Data Clock (\overline{WR} Pin)	3V	Duty cycle 50%	—	—	150	kHz
		5V		—	—	300	
f _{CLK2}	4-Bit Data Clock (\overline{RD} Pin)	3V	Duty cycle 50%	—	—	75	kHz
		5V		—	—	150	
t _{CS}	4-Bit Interface Reset Pulse Width (Figure 3)	—	\overline{CS}	—	250	—	ns
t _{CLK}	\overline{WR} , \overline{RD} Input Pulse Width (Figure 1)	3V	Write mode	3.34	—	—	μs
			Read mode	6.67			
		5V	Write mode	1.67	—	—	μs
			Read mode	3.34			
t _r , t _f	Rise/Fall Time Serial Data Clock Width (Figure 1)	3V	—	—	120	—	ns
		5V					
t _{su}	Setup Time for DB to \overline{WR} , \overline{RD} Clock Width (Figure 2)	3V	—	—	120	—	ns
		5V					
t _h	Hold Time for DB to \overline{WR} , \overline{RD} Clock Width (Figure 2)	3V	—	—	120	—	ns
		5V					
t _{su1}	Setup Time for \overline{CS} to \overline{WR} , \overline{RD} Clock Width (Figure 3)	3V	—	—	100	—	ns
		5V					
t _{h1}	Hold Time for \overline{CS} to \overline{WR} , \overline{RD} Clock Width (Figure 3)	3V	—	—	100	—	ns
		5V					

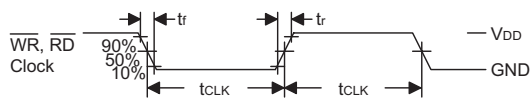

Figure 1

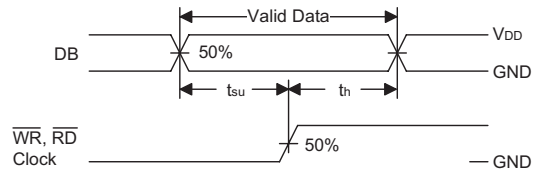

Figure 2

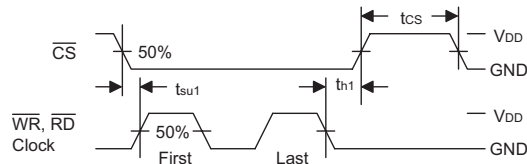

Figure 3

Functional Description

System Oscillator

The HT1660 system clock is used to generate the time base/Watchdog Timer (WDT) clock frequency, LCD driving clock, and tone frequency. The clock source may be from an on-chip RC oscillator (32kHz), a crystal oscillator (32.768kHz), or an external 32kHz clock by the S/W setting. The configuration of the system oscillator is as shown. After the SYS DIS command is executed, the system clock will stop and the LCD bias generator will turn off. That command is available only for the on-chip RC oscillator or for the crystal oscillator. Once the system clock stops, the LCD display will become blank, and the time base/WDT loses its function as well.

The LCD OFF command is used to turn the LCD bias generator off. After the LCD bias generator switches off by issuing the LCD OFF command, using the SYS DIS command reduces power consumption, thus serving as a system power down command. But if the external clock source is chosen as the system clock, using the SYS DIS command can neither turn the oscillator off nor carry out the power down mode. The crystal oscillator option can be applied to connect an external frequency source of 32kHz to the OSC1 pin. In this case, the system fails to enter the power down mode, similar to the case in the external 32kHz clock source operation. At the initial system power on, the HT1660 is at the SYS DIS state.

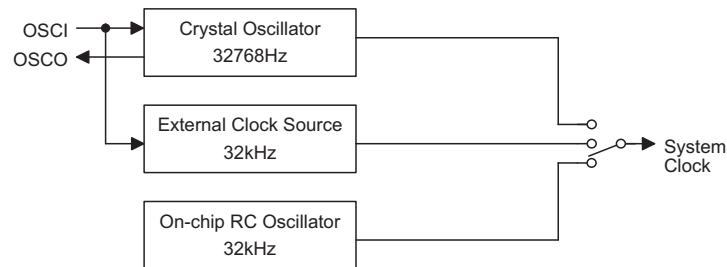

System Oscillator Configuration

Display Memory – RAM Structure

The static display RAM is organized into 768×4 bits and stores the display data. The contents of the RAM are directly mapped to the contents of the LCD driver. Data in the RAM can be accessed by the READ, WRITE and READ-MODIFY-WRITE commands. The following is a mapping from the RAM to the LCD patterns.

	00H	08H	10H	18H	20H - - - - - 2D8H	2E0H	2E8H	2F0H	2F8H
COM0	Bit0	Bit0	Bit0				Bit0	Bit0	Bit0
COM1	Bit1	Bit1	Bit1				Bit1	Bit1	Bit1
COM2	Bit2	Bit2	Bit2				Bit2	Bit2	Bit2
COM3	Bit3	Bit3	Bit3				Bit3	Bit3	Bit3
	01H	09H	11H	19H	21H - - - - - 2D9H	2E1H	2E9H	2F1H	2F9H
COM4	Bit0	Bit0	Bit0				Bit0	Bit0	Bit0
COM5	Bit1	Bit1	Bit1				Bit1	Bit1	Bit1
COM6	Bit2	Bit2	Bit2				Bit2	Bit2	Bit2
COM7	Bit3	Bit3	Bit3				Bit3	Bit3	Bit3
	02H	0AH	12H	1AH	22H - - - - - 2DAH	2E2H	2EAH	2F2H	2FAH
COM8	Bit0	Bit0	Bit0				Bit0	Bit0	Bit0
COM9	Bit1	Bit1	Bit1				Bit1	Bit1	Bit1
COM10	Bit2	Bit2	Bit2				Bit2	Bit2	Bit2
COM11	Bit3	Bit3	Bit03				Bit3	Bit3	Bit3
	03H	0BH	13H	1BH	23H - - - - - 2DBH	2E3H	2EBH	2F3H	2FBH
COM12	Bit0	Bit0	Bit0				Bit0	Bit0	Bit0
COM13	Bit1	Bit1	Bit1				Bit1	Bit1	Bit1
COM14	Bit2	Bit2	Bit2				Bit2	Bit2	Bit2
COM15	Bit3	Bit3	Bit3				Bit3	Bit3	Bit3
	04H	0CH	14H	1CH	24H - - - - - 2DCH	2E4H	2ECH	2F4H	2FCH
COM16	Bit0	Bit0	Bit0				Bit0	Bit0	Bit0
COM17	Bit1	Bit1	Bit1				Bit1	Bit1	Bit1
COM18	Bit2	Bit2	Bit2				Bit2	Bit2	Bit2
COM19	Bit3	Bit3	Bit3				Bit3	Bit3	Bit3
	05H	0DH	15H	1DH	25H - - - - - 2DDH	2E5H	2EDH	2F5H	2FDH
COM20	Bit0	Bit0	Bit0				Bit0	Bit0	Bit0
COM21	Bit1	Bit1	Bit1				Bit1	Bit1	Bit1
COM22	Bit2	Bit2	Bit2				Bit2	Bit2	Bit2
COM23	Bit3	Bit3	Bit3				Bit3	Bit3	Bit3
	06H	0EH	16H	1EH	26H - - - - - 2DEH	2E6H	2EEH	2F6H	2FEH
COM24	Bit0	Bit0	Bit0				Bit0	Bit0	Bit0
COM25	Bit1	Bit1	Bit1				Bit1	Bit1	Bit1
COM26	Bit2	Bit2	Bit2				Bit2	Bit2	Bit2
COM27	Bit3	Bit3	Bit3				Bit3	Bit3	Bit3
	07H	0FH	17H	1FH	27H - - - - - 2DFH	2E7H	2EFH	2F7H	2FFH
COM28	Bit0	Bit0	Bit0				Bit0	Bit0	Bit0
COM29	Bit1	Bit1	Bit1				Bit1	Bit1	Bit1
COM30	Bit2	Bit2	Bit2				Bit2	Bit2	Bit2
COM31	Bit3	Bit3	Bit3				Bit3	Bit3	Bit3
	SEG0	SEG1	SEG2	SEG3		SEG92	SEG93	SEG94	SEG95

96×32 Selection Mode RAM Mapping Table

	00H	04H	08H	0CH	10H-----1ACH	1B0H	1B4H	1B8H	1BCH
COM0	Bit0	Bit0	Bit0				Bit0	Bit0	Bit0
COM1	Bit1	Bit1	Bit1				Bit1	Bit1	Bit1
COM2	Bit2	Bit2	Bit2				Bit2	Bit2	Bit2
COM3	Bit3	Bit3	Bit3				Bit3	Bit3	Bit3
	01H	05H	09H	0DH	11H-----1ADH	1B1H	1B5H	1B9H	1BDH
COM4	Bit0	Bit0	Bit0				Bit0	Bit0	Bit0
COM5	Bit1	Bit1	Bit1				Bit1	Bit1	Bit1
COM6	Bit2	Bit2	Bit2				Bit2	Bit2	Bit2
COM7	Bit3	Bit3	Bit3				Bit3	Bit3	Bit3
	02H	06H	0AH	0EH	12H-----1AEH	1B2H	1B6H	1BAH	1BEH
COM8	Bit0	Bit0	Bit0				Bit0	Bit0	Bit0
COM9	Bit1	Bit1	Bit1				Bit1	Bit1	Bit1
COM10	Bit2	Bit2	Bit2				Bit2	Bit2	Bit2
COM11	Bit3	Bit3	Bit3s				Bit3	Bit3	Bit3
	03H	07H	0BH	0FH	13H-----1AFH	1B3H	1B7H	1BBH	1BFH
COM12	Bit0	Bit0	Bit0				Bit0	Bit0	Bit0
COM13	Bit1	Bit1	Bit1				Bit1	Bit1	Bit1
COM14	Bit2	Bit2	Bit2				Bit2	Bit2	Bit2
COM15	Bit3	Bit3	Bit3				Bit3	Bit3	Bit3
	SEG0	SEG1	SEG2	SEG3		SEG108	SEG109	SEG110	SEG111

112×16 Selection Mode RAM Mapping Table

Name	Command Code	Function
112×16 Mode	X100-0001-1111-XXXX	Change segment from 96 to 112 and common from 32 to 16
The default value after power ON reset is 96×32 mode, set "Normal" command will change 112×16 mode to 96×32 mode.		

Frame Frequency

HT1660 provides three kinds of frame frequency option by command code; 64Hz, 89Hz and 170Hz respectively. FRAME 64Hz provides 64Hz frame frequency. FRAME 89Hz provides 89Hz frame frequency. FRAME 170Hz provides 170Hz frame frequency.

Name	Command Code	Function
FRAME 170Hz	X100-0001-1000-XXXX	Select 170Hz frame frequency
FRAME 89Hz	X100-0001-1101-XXXX	Select 89Hz frame frequency
FRAME 64Hz	X100-0001-1110-XXXX	Select 64Hz frame frequency

Frame Frequency Selection Command Code
Time Base and Watchdog Timer – WDT

The time base generator and WDT share the same counter which is divided by 256. The \overline{IRQ} clock can be programmed as 1Hz, 2Hz, ..., 128Hz output. TIMER DIS/EN/CLR, WDT DIS/EN/CLR and \overline{IRQ} EN/DIS are independent from each other. Once the WDT time-out occurs, the \overline{IRQ} pin will remain at a logic low level until the CLR WDT or the \overline{IRQ} DIS command is issued.

If an external clock is selected as the system frequency source, the SYS DIS command turns out invalid and the power down mode fails to be carried out until the external clock source is removed.

Buzzer Tone Output

A simple tone generator is implemented in the HT1660. The tone generator can output a pair of differential driving signals on the BZ and \overline{BZ} which are used to generate a single tone.

By executing the TONE 4K and TONE 2K commands there are two tone frequency outputs selectable that can turn on the tone output. The TONE 4K and TONE 2K commands set the tone frequency to 4kHz and 2kHz, respectively. The tone output can be turned off by invoking the TONE OFF command. The tone outputs, namely BZ and \overline{BZ} , are a pair of differential driving outputs used to drive a piezo buzzer. Once the system is disabled or the tone output is inhibited, the BZ and the \overline{BZ} outputs will remain at low level.

Command Format

The HT1660 can be configured by software setting. There are two mode commands to configure the HT1660 resource and to transfer the LCD display data.

The configuration mode of the HT1660 is called command mode, and its command mode ID is 100. The command mode consists of a system configuration

command, a system frequency selection command, an LCD configuration command, a tone frequency selection command, a bias current selection command, a timer/WDT setting command, and an operating command. The data mode, on the other hand, includes READ, WRITE, and READ-MODIFY-WRITE operations.

The following are the data mode ID and the command mode ID:

Operation	Mode	ID
READ	Data	110
WRITE	Data	101
READ-MODIFY-WRITE	Data	101
COMMAND	Command	100

If successive commands have been issued, the command mode ID can be omitted. While the system is operating in the non-successive command or the non-successive address data mode, the \overline{CS} pin should be set to "1" and the previous operation mode will also be reset. The \overline{CS} pin returns to "0", so a new operation mode ID should be issued first.

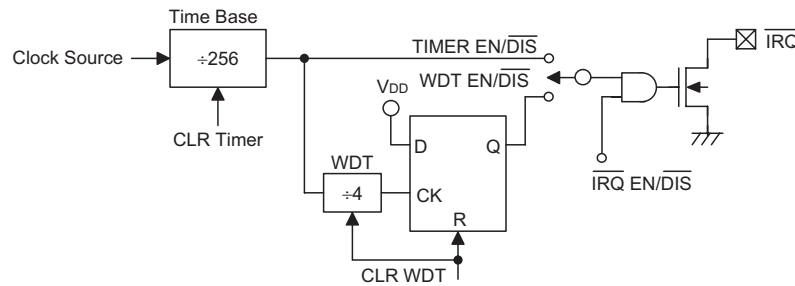

Time Base and WDT Configurations

Name	Command Code	Function
TONE OFF	X100-0000-1000-XXXX	Turn-off tone output
TONE 4K	X100-0001-0000-XXXX	Turn-on tone output, tone frequency is 4kHz
TONE 2K	X100-0001-0001-XXXX	Turn-on tone output, tone frequency is 2kHz

Buzzer Tone Output Command Code

The following are the data mode ID and the command ID:

Operation	Mode	ID
READ	Data	110
WRITE	Data	101
READ-MODIFY-WRITE	Data	101
COMMAND	Command	100

If successive commands have been issued, the command mode ID can be omitted. While the system is operating in the non-successive address data mode, the \overline{CS} pin should be set 1 and the previous operation mode will also be reset. The \overline{CS} pin returns to 0, so a new operation mode ID should be issued first.

Bias Generator

The HT1660 bias voltage belongs to internal resistor type. It provides two kinds of bias option named 1/6 bias and 1/5 bias respectively. It also provides three kinds of bias current option by programming to suitably drive an LCD panel. The three kinds of bias current are large, middle, and small, respectively. Usually, large panel LCD can be excellently displayed by large bias current. Relatively, it consumes large current when LCD ON command is used. Small bias current provides low power consumption during on condition when the LCD is normally displayed. The following are the reference value table.

When the bias current for LCD is more than Large Bias Current setting. It is recommended to add external circuit to increase driving current.

Interfacing

Only six lines are required to interface with the HT1660. The CS line is used to initialize the serial interface circuit and to terminate the communication between the host controller and the HT1660. If the CS pin is set to 1, the

data and command issued between the host controller and the HT1660 are first disabled and then initialized. Before issuing a mode command or mode switching, a high level pulse is required to initialize the serial interface of the HT1660. The DB0~DB3 are the 4-bit parallel data input/output lines. Data to be read or written or commands to be written have to pass through the DB0~DB3 lines. The RD line is the READ clock input. Data in the RAM are clocked out on the falling edge of the RD signal, and the clocked out data will then appear on the DB0~DB3 lines. It is recommended that the host controller read correct data during the interval between the rising edge and the next falling edge of the RD signal. The WR line is the WRITE clock input. The data, address, and command on the DB0~DB3 lines are all clocked into the HT1660 on the rising edge of the WR signal. There is an optional IRQ line to be used as an interface between the host controller and the HT1660. The IRQ pin can be selected as a timer output or a WDT overflow flag output by the S/W setting. The host controller can perform the time base or the WDT function by connecting with the IRQ pin of the HT1660.

Bias	V CD	arge Bias Current	Middle Bias Current	Small Bias Current
1/5	3V	165μA	70μA	30μA
	5V	270μA	110μA	50μA
1/6	3V	140μA	55μA	25μA
	5V	225μA	90μA	40μA

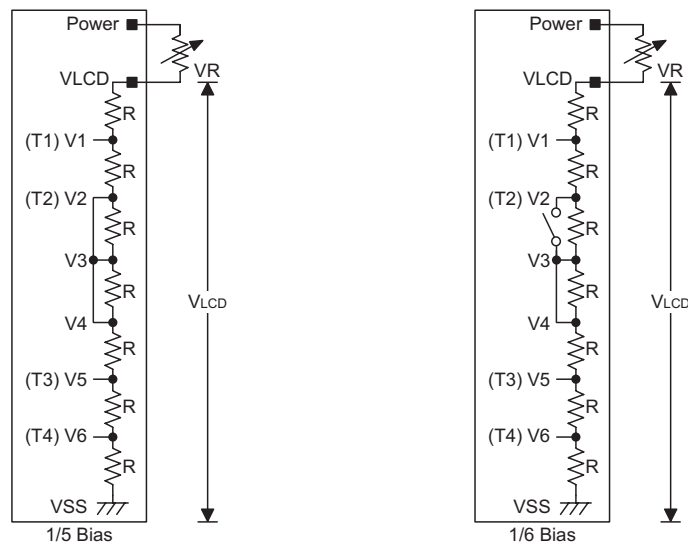

Internal Resistor Type Bias Generator Configurations

Note: The voltage applied to VLCD pin must be lower than 7V
Adjust VR to fit LCD display

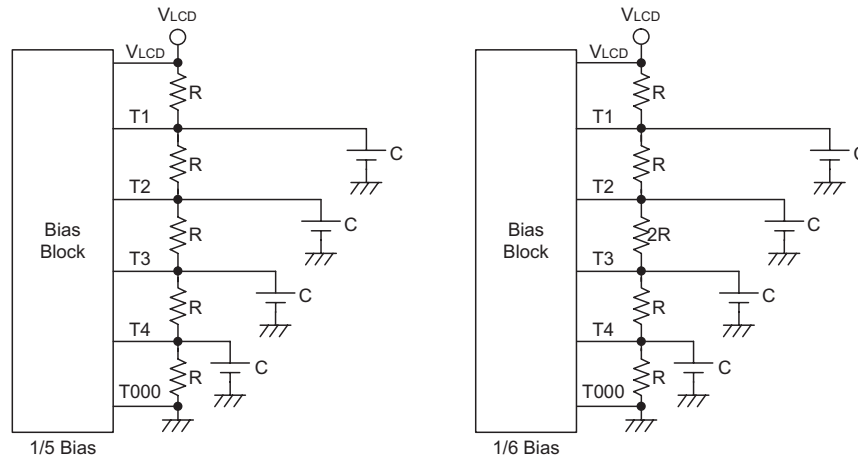

Increase Driver Current Configurations

Note: The external resistors are used to increment the driving current.
 And the external capacitors are used to keep the bias voltage stable.

Timing Diagrams

READ Mode (Command ID Code: 1 1 0)

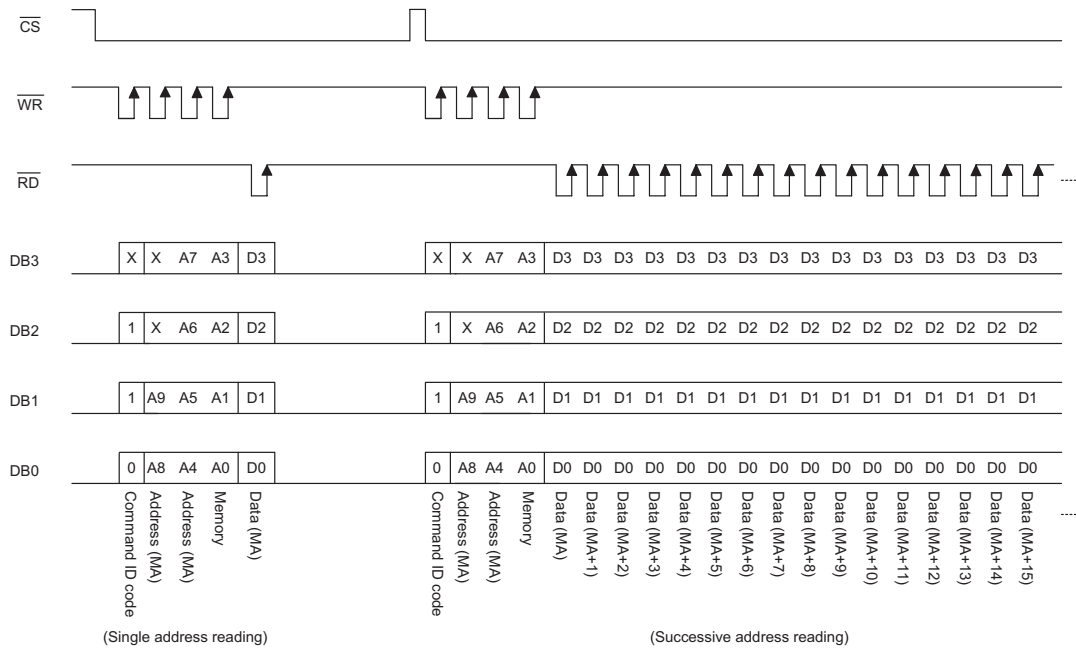

WRITE Mode (Command ID Code: 1 0 1)

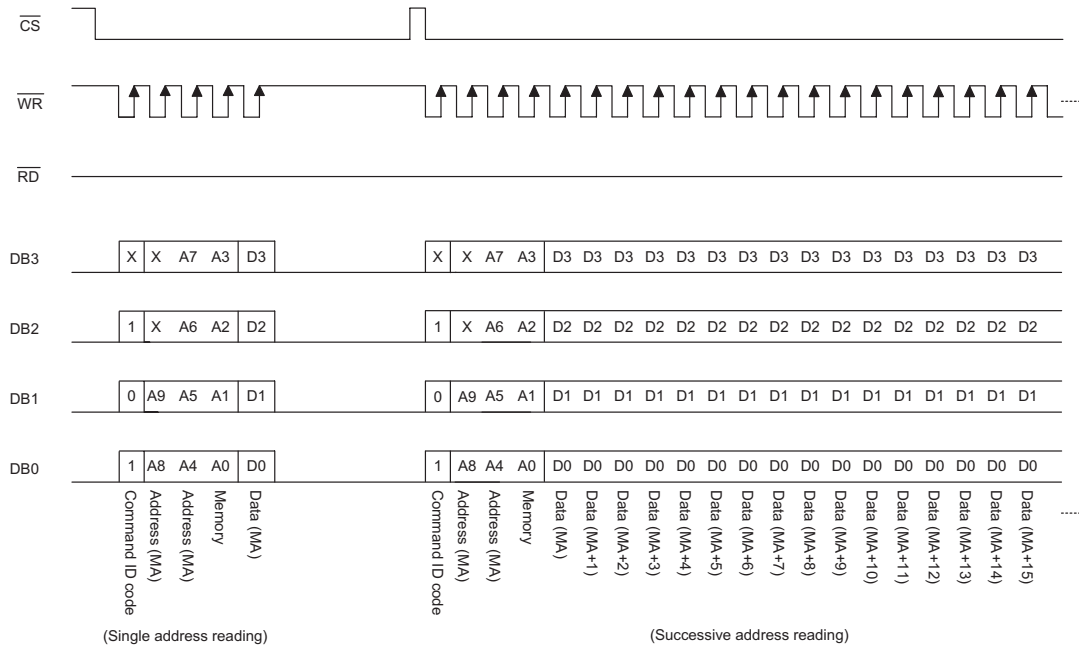

READ-MODIFY-WRITE Mode (Command ID Code: 1 0 1)

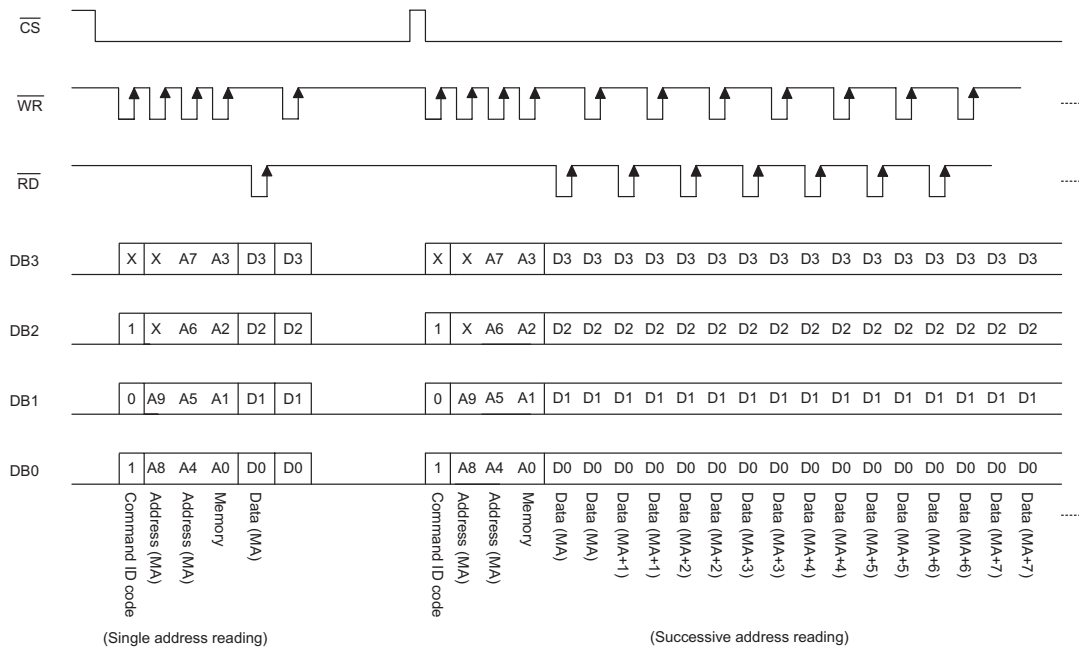

Command Mode (Command ID Code: 1 0 0)

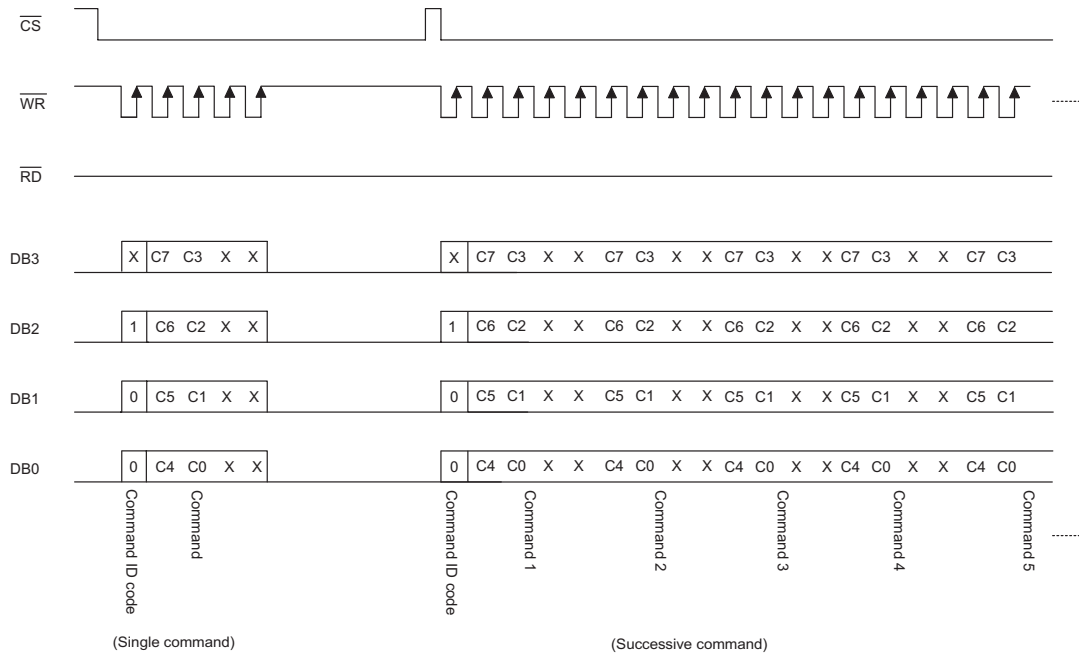

Note: "X" stands for don't care

Application Circuits

Host Controller With an HT1660 Display System

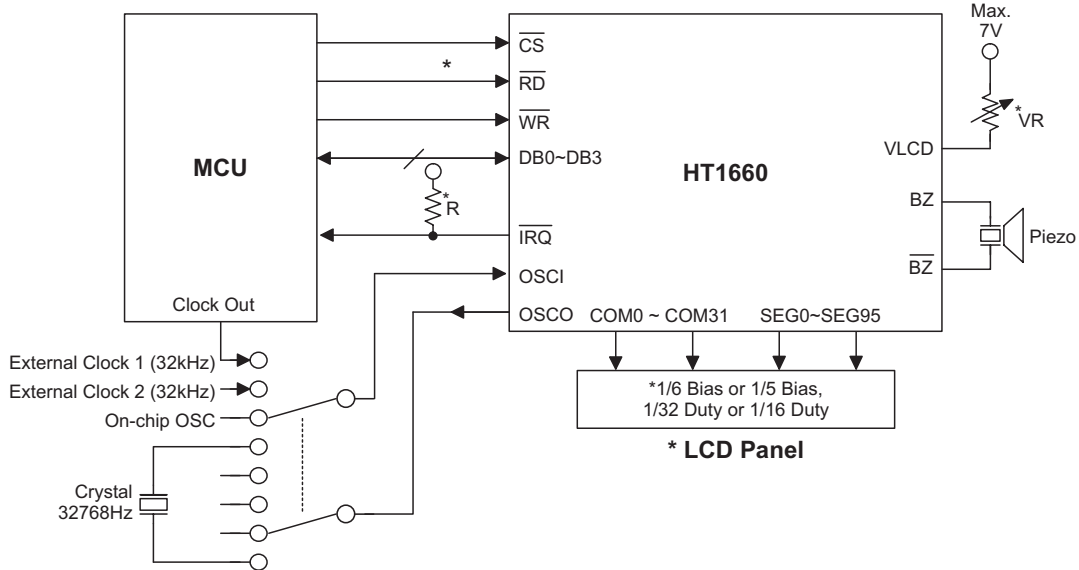

*Note: The connection of \overline{IRQ} and \overline{RD} pin can be selected depending on the MCU.

Adjust VR to fit LCD display

Adjust R (external pull-high resistance) to fit user's time base clock.

It is recommended that the internal equivalent capacitance between SEG and COM of LCD panel should be lower than 10pF. (LCR meter test condition: frequency in 1KHz)

Instruction Set Summary

Name	Command Code	D/C	Function	Def.
READ	X110-XXA9A8-A7A6A5A4-A3A2A1A0-D3D2D1D0	D	Read data from the RAM	
WRITE	X101-XXA9A8-A7A6A5A4-A3A2A1A0-D3D2D1D0	D	Write data to the RAM	
READ-MODIFY-WRITE	X101-XXA9A8-A7A6A5A4-A3A2A1A0-D3D2D1D0	D	Read and Write data to the RAM	
SYS DIS	X100-0000-0000-XXXX-XXXX	C	Turn Off both system oscillator and LCD bias generator	Yes
SYS EN	X100-0000-0001-XXXX-XXXX	C	Turn On system oscillator	
LCD OFF	X100-0000-0010-XXXX-XXXX	C	Turn Off LCD display	Yes
LCD ON	X100-0000-0011-XXXX-XXXX	C	Turn On LCD display	
TIMER DIS	X100-0000-0100-XXXX-XXXX	C	Disable time base output	Yes
WDT DIS	X100-0000-0101-XXXX-XXXX	C	Disable WDT time-out flag output	Yes
TIMER EN	X100-0000-0110-XXXX-XXXX	C	Enable time base output	
WDT EN	X100-0000-0111-XXXX-XXXX	C	Enable WDT time-out flag output	
TONE OFF	X100-0000-1000-XXXX-XXXX	C	Turn Off tone outputs	Yes
CLR TIMER	X100-0000-1101-XXXX-XXXX	C	Clear the contents of the time base generator	
CLR WDT	X100-0000-1111-XXXX-XXXX	C	Clear the contents of the WDT stage	
TONE 4K	X100-0001-0000-XXXX-XXXX	C	Turn on tone output, tone frequency output: 4kHz	
TONE 2K	X100-0001-0001-XXXX-XXXX	C	Turn on tone output, tone frequency output: 2kHz	
IRQ DIS	X100-0001-0010-XXXX-XXXX	C	Disable $\overline{\text{IRQ}}$ output	Yes
IRQ EN	X100-0001-0011-XXXX-XXXX	C	Enable $\overline{\text{IRQ}}$ output	
RC 32K	X100-0001-0100-XXXX-XXXX	C	System clock source, on-chip RC oscillator	Yes
EXT (X'TAL)	X100-0001-0101-XXXX-XXXX	C	System clock source, external 32kHz clock source or crystal oscillator 32.768kHz	
LARGE BIAS	X100-0001-0110-XXXX-XXXX	C	Large bias current option	Yes
MIDDLE BIAS	X100-0001-0111-XXXX-XXXX	C	Middle bias current option	
SMALL BIAS	X100-0001-1000-XXXX-XXXX	C	Small bias current option	
BIAS 1/6	X100-0001-1010-XXXX-XXXX	C	LCD 1/6 bias option	Yes
BIAS 1/5	X100-0001-1001-XXXX-XXXX	C	LCD 1/5 bias option	
FRAME 170Hz	X100-0001-1100-XXXX-XXXX	C	Selects 170Hz frame frequency	
FRAME 89Hz	X100-0001-1101-XXXX-XXXX	C	Selects 89Hz frame frequency	
FRAME 64Hz	X100-0001-1110-XXXX-XXXX	C	Selects 64Hz frame frequency	Yes
Select 112x16	X100-0001-1111-XXXX-XXXX	C	This command will change segment from 96 to 112 and command from 32 to 16	
F1	X100-1010-0000-XXXX-XXXX	C	Time base clock output: 1Hz The WDT time-out flag after: 4s	
F2	X100-1010-0001-XXXX-XXXX	C	Time base clock output: 2Hz The WDT time-out flag after: 2s	
F4	X100-1010-0010-XXXX-XXXX	C	Time base clock output: 4Hz The WDT time-out flag after: 1s	

Name	Command Code	D/C	Function	Def.
F8	X100-1010-0011-XXXX-XXXX	C	Time base clock output: 8Hz The WDT time-out flag after: 1/2s	
F16	X100-1010-0100-XXXX-XXXX	C	Time base clock output: 16Hz The WDT time-out flag after: 1/4s	
F32	X100-1010-0101-XXXX-XXXX	C	Time base clock output: 32Hz The WDT time-out flag after: 1/8s	
F64	X100-1010-0110-XXXX-XXXX	C	Time base clock output: 96Hz The time-out flag after: 1/16s	
F128	X100-1010-0111-XXXX-XXXX	C	Time base clock output: 128Hz The WDT time-out flag after: 1/32s	Yes
TEST	X100-1111-1111-XXXX-XXXX	C	Test mode, user don't use.	
NORMAL	X100-1111-1110-XXXX-XXXX	C	Normal mode, 96×32 mode will be set	Yes

Note: "X" stands for don't care

A9~A0: RAM address

D3~D0: RAM data

D/C: Data/Command mode

Def.: Power-on reset default

All the bold forms, namely **1 1 0**, **1 0 1**, and **1 0 0**, are mode commands. Of these, **1 0 0** indicates the command mode ID. If successive commands have been issued, the command mode ID except for the first command will be omitted. The tone frequency source and the time base/WDT clock frequency source can be derived from an on-chip 32kHz RC oscillator, a 32.768kHz crystal oscillator, or an external 32kHz clock. Calculation of the frequency is based on the system frequency sources as stated above. It is recommended that the host controller should initialize the HT1660 after power-on reset, otherwise, power on reset may fail, which in turn leads to the malfunctioning of the HT1660.

Package Information

160-pin QFP (28×28) Outline Dimensions

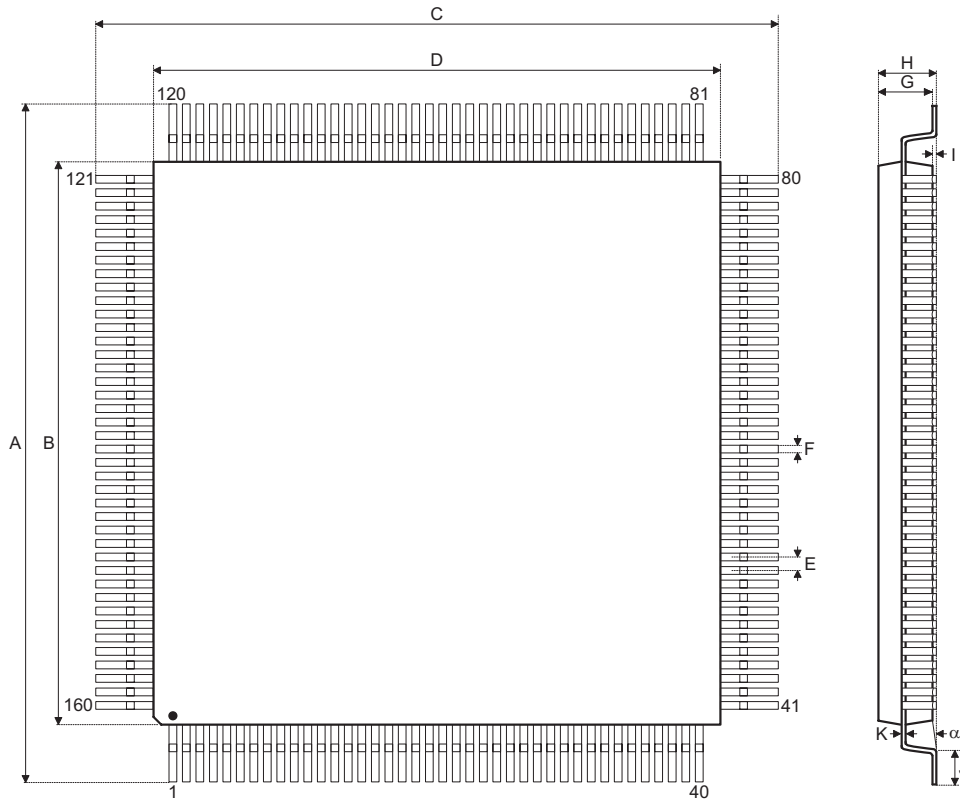

Symbol	Dimensions in mm		
	Min.	Nom.	Max.
A	31	—	31.40
B	27.90	—	28.10
C	31	—	31.40
D	27.90	—	28.10
E	—	0.65	—
F	—	0.30	—
G	3.10	—	3.40
H	—	—	3.70
I	—	0.10	—
J	0.65	—	0.95
K	0.10	—	0.20
α	0°	—	7°

Holtek Semiconductor Inc. (Headquarters)

No.3, Creation Rd. II, Science Park, Hsinchu, Taiwan
Tel: 886-3-563-1999
Fax: 886-3-563-1189
<http://www.holtek.com.tw>

Holtek Semiconductor Inc. (Taipei Sales Office)

4F-2, No. 3-2, YuanQu St., Nankang Software Park, Taipei 115, Taiwan
Tel: 886-2-2655-7070
Fax: 886-2-2655-7373
Fax: 886-2-2655-7383 (International sales hotline)

Holtek Semiconductor Inc. (Shanghai Sales Office)

7th Floor, Building 2, No.889, Yi Shan Rd., Shanghai, China 200233
Tel: 021-6485-5560
Fax: 021-6485-0313
<http://www.holtek.com.cn>

Holtek Semiconductor Inc. (Shenzhen Sales Office)

43F, SEG Plaza, Shen Nan Zhong Road, Shenzhen, China 518031
Tel: 0755-8346-5589
Fax: 0755-8346-5590
ISDN: 0755-8346-5591

Holtek Semiconductor Inc. (Beijing Sales Office)

Suite 1721, Jinyu Tower, A129 West Xuan Wu Men Street, Xicheng District, Beijing, China 100031
Tel: 010-6641-0030, 6641-7751, 6641-7752
Fax: 010-6641-0125

Holmate Semiconductor, Inc. (North America Sales Office)

46712 Fremont Blvd., Fremont, CA 94538
Tel: 510-252-9880
Fax: 510-252-9885
<http://www.holmate.com>

Copyright © 2005 by HOLTEK SEMICONDUCTOR INC.

The information appearing in this Data Sheet is believed to be accurate at the time of publication. However, Holtek assumes no responsibility arising from the use of the specifications described. The applications mentioned herein are used solely for the purpose of illustration and Holtek makes no warranty or representation that such applications will be suitable without further modification, nor recommends the use of its products for application that may present a risk to human life due to malfunction or otherwise. Holtek's products are not authorized for use as critical components in life support devices or systems. Holtek reserves the right to alter its products without prior notification. For the most up-to-date information, please visit our web site at <http://www.holtek.com.tw>.