

**INTRODUCTION**

**100 QFP**

KS0083/84 is a graphic type LCD driver LSI which is fabricated by CMOS process for high voltage. In case of segment driver, can be selected 4 bit, 1 bit data transfer or chip select mode. KS0084 is reverse type of KS0083

**FUNCTION**

- Dot matrix LCD driver with 80 channel output.
- Input/Output
  - Output: 80 channel waveform for LCD driving
  - Input: • parallel display data and control signal from controller
    - bias voltage ( $V_3, V_4, V_{SS}, V_{EE}$ )

**FEATURES**

- Power supply voltage:  $+5V \pm 10\%$  ( $V_{DD}$ )
- LCD driving voltage:  $-24V$ (typ) ( $V_{EE}$ )
- Interface

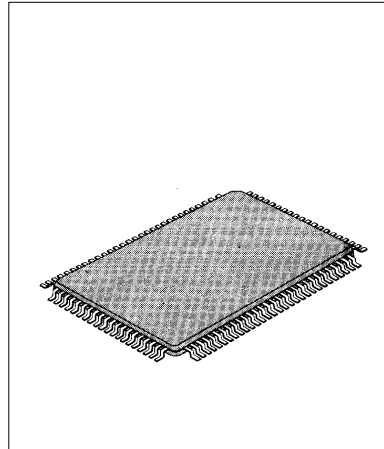

type 1		type 2		type 3	
COMMON	SEGMENT	COMMON	SEGMENT	COMMON	SEGMENT
KS0083/84	KS0083/84	KS0103	KS0083/84	KS0083/84	KS0104/B
KS0086	KS0086		KS0086	KS0086	

- I00QFP and bare chip available

**BLOCK DIAGRAM**

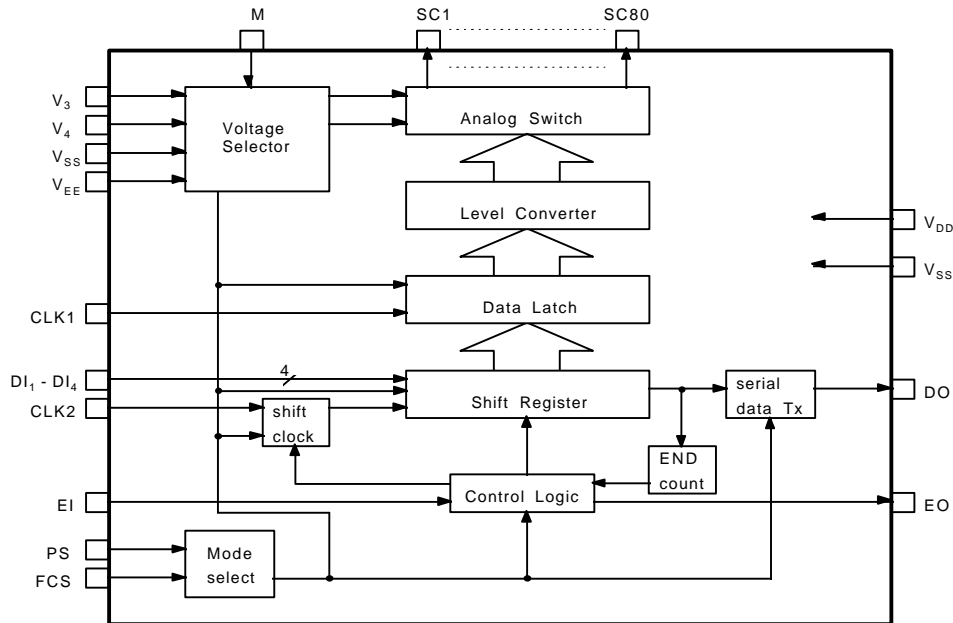

Fig. 1 KS0083/84 functional block diagram.

PIN CONFIGURATION

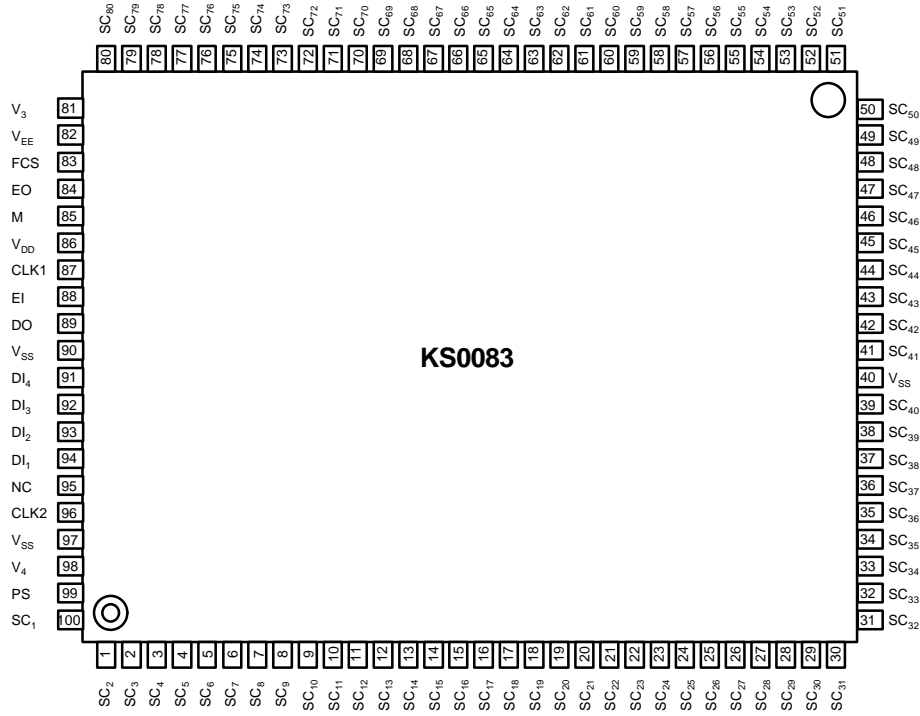

Fig. 2. 100 QFP Top View

PIN CONFIGURATION

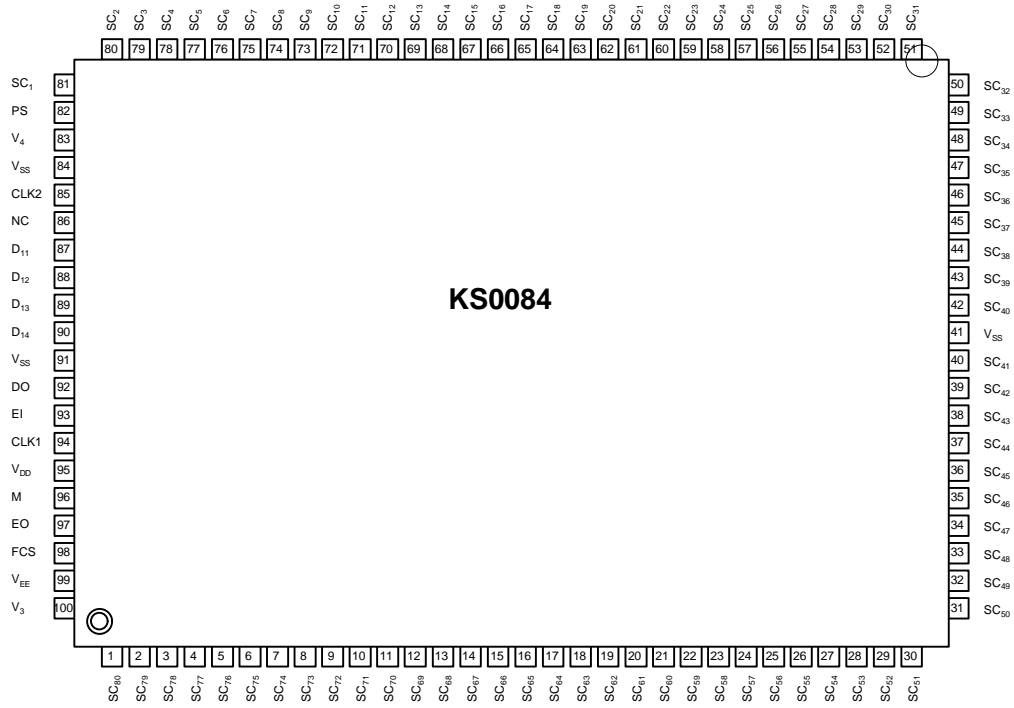

Fig.3 100QFP Top View.

**PIN FUNCTIONAL DESCRIPTION**

PIN		INPUT OUTPUT	DESCRIPTION	INTERFACE																														
Power Supply	V <sub>SS</sub>	Power	GND(0V)																															
	V <sub>EE</sub>		LCD driving voltage (typ.-24V)																															
	V <sub>DD</sub>		Internal logic driving voltage (typ.-5V)																															
V <sub>3</sub> , V <sub>4</sub>		Input	Bias Voltage input for LCD drive: Non-select Level (Must maintain V <sub>SS</sub> >V <sub>3</sub> >V <sub>4</sub> >V <sub>EE</sub> .)	LCD																														
SC <sub>1</sub> ~ SC <sub>80</sub>		Output	LCD driver output terminal (80 Channel)	LCD																														
FCS, PS		Input	Mode select inputs. (refer to application circuit)																															
			<table border="1"> <thead> <tr> <th>FCS</th> <th>PS</th> <th>Com/Seg driver</th> <th>Input mode</th> <th>Chip select mode</th> <th>DO Output</th> </tr> </thead> <tbody> <tr> <td>L</td> <td>L</td> <td>Segment driver</td> <td>1 bit serial input</td> <td>X</td> <td>O</td> </tr> <tr> <td>L</td> <td>H</td> <td>Segment driver</td> <td>4 bit parallel input</td> <td>O</td> <td>H</td> </tr> <tr> <td>H</td> <td>L</td> <td>Segment driver</td> <td>1 bit serial input</td> <td>X</td> <td>H</td> </tr> <tr> <td>H</td> <td>H</td> <td>Common driver</td> <td>Serial input</td> <td>O</td> <td>O</td> </tr> </tbody> </table>		FCS	PS	Com/Seg driver	Input mode	Chip select mode	DO Output	L	L	Segment driver	1 bit serial input	X	O	L	H	Segment driver	4 bit parallel input	O	H	H	L	Segment driver	1 bit serial input	X	H	H	H	Common driver	Serial input	O	O
FCS	PS	Com/Seg driver	Input mode		Chip select mode	DO Output																												
L	L	Segment driver	1 bit serial input		X	O																												
L	H	Segment driver	4 bit parallel input		O	H																												
H	L	Segment driver	1 bit serial input		X	H																												
H	H	Common driver	Serial input		O	O																												
			- In case of serial input mode, DI1 is data input pin and DO is data output pin - In case of 4 bit parallel input mode, Data input and output are;																															
			<table border="1"> <tbody> <tr> <td>DI<sub>1</sub></td> <td>SC<sub>1</sub>, SC<sub>5</sub>, ... SC<sub>77</sub></td> <td>DI<sub>2</sub></td> <td>SC<sub>2</sub>, SC<sub>6</sub>, ... SC<sub>78</sub></td> </tr> <tr> <td>DI<sub>3</sub></td> <td>SC<sub>3</sub>, SC<sub>7</sub>, ... SC<sub>70</sub></td> <td>DI<sub>4</sub></td> <td>SC<sub>4</sub>, SC<sub>8</sub>, ... SC<sub>80</sub></td> </tr> </tbody> </table>		DI <sub>1</sub>	SC <sub>1</sub> , SC <sub>5</sub> , ... SC <sub>77</sub>	DI <sub>2</sub>	SC <sub>2</sub> , SC <sub>6</sub> , ... SC <sub>78</sub>	DI <sub>3</sub>	SC <sub>3</sub> , SC <sub>7</sub> , ... SC <sub>70</sub>	DI <sub>4</sub>	SC <sub>4</sub> , SC <sub>8</sub> , ... SC <sub>80</sub>																						
DI <sub>1</sub>	SC <sub>1</sub> , SC <sub>5</sub> , ... SC <sub>77</sub>	DI <sub>2</sub>	SC <sub>2</sub> , SC <sub>6</sub> , ... SC <sub>78</sub>																															
DI <sub>3</sub>	SC <sub>3</sub> , SC <sub>7</sub> , ... SC <sub>70</sub>	DI <sub>4</sub>	SC <sub>4</sub> , SC <sub>8</sub> , ... SC <sub>80</sub>																															
			<table border="1"> <thead> <tr> <th colspan="4">4 bit Data shift direction</th> <th colspan="4">1 bit Data shift</th> </tr> </thead> <tbody> <tr> <td colspan="4"> </td> <td colspan="4"> </td> </tr> </tbody> </table>	4 bit Data shift direction				1 bit Data shift																										
4 bit Data shift direction				1 bit Data shift																														
			- In case of the common driver, the data transfer clock is CLK2 - Non-used data input pins are set to V <sub>SS</sub> or V <sub>DD</sub> to minimize current consumption																															

## PIN DESCRIPTION(continued)

PIN	INPUT OUTPUT	DESCRIPTION	INTERFACE																										
EO, EI	Input Output	<p>Input/Output for Chip Select.</p> <p>1) EO becomes low by (CLK1, CLK2) timing.</p> <p>2) When "HIGH" data is input to EI, the device becomes select mode and reads input data at CLK2 falling timing. Synchronized at the fall of CLK2. Input data is shifted.</p> <p>3) After reading 80 input data(equivalent to 80 CLK2 clock cycle in the serial mode or 20 CLK2 clock cycles in the 4 bit parallel,mode) ,EO automatically becomes " HIGH" level and data reading is complete. EO is reset 1.5 cycles later.</p> <p>4) When two or more devices are used in the chip select mode, EO of each state is connected to EI of the next state.</p> <p>(1) EO of all device connected is reset and device becomes non-select state and waits for EI input after the previous 1).</p> <p>(2) When "HIGH" level is input to the first EI in the cascade connection, the first device performs the operation in 2) and 3).</p> <p>(3) When EI of the second device is connected to EO of the first device, the second device perform the operations 2) and 3) after the first device. This operation is repeated in the same method subsequently</p>	Controller or KS0083/84																										
M	Input	<p>LCD waveform AC conversion signal input</p> <table border="1" style="width: 100%; border-collapse: collapse;"> <thead> <tr> <th>Latch data</th> <th>M</th> <th>SC</th> <th>Latch data</th> <th>M</th> <th>SC</th> </tr> </thead> <tbody> <tr> <td rowspan="2">L (non-select)</td> <td>L</td> <td>V<sub>3</sub></td> <td rowspan="2">L (non-select)</td> <td>L</td> <td>V<sub>3</sub></td> </tr> <tr> <td>H</td> <td>V<sub>4</sub></td> <td>H</td> <td>V<sub>4</sub></td> </tr> <tr> <td rowspan="2">H (select)</td> <td>L</td> <td>GND</td> <td rowspan="2">H (select)</td> <td>L</td> <td>V<sub>EE</sub></td> </tr> <tr> <td>H</td> <td>V<sub>EE</sub></td> <td>H</td> <td>GND</td> </tr> </tbody> </table> <p>(segment signal drive mode) (common signal drive mode)</p>	Latch data	M	SC	Latch data	M	SC	L (non-select)	L	V <sub>3</sub>	L (non-select)	L	V <sub>3</sub>	H	V <sub>4</sub>	H	V <sub>4</sub>	H (select)	L	GND	H (select)	L	V <sub>EE</sub>	H	V <sub>EE</sub>	H	GND	Controller
Latch data	M	SC	Latch data	M	SC																								
L (non-select)	L	V <sub>3</sub>	L (non-select)	L	V <sub>3</sub>																								
	H	V <sub>4</sub>		H	V <sub>4</sub>																								
H (select)	L	GND	H (select)	L	V <sub>EE</sub>																								
	H	V <sub>EE</sub>		H	GND																								
CLK1	Input	Clock pulse input terminal for data latch	Controller																										
CLK2	Input	Clock pulse input terminal for data shift	Controller																										
DI1 ~ DI4	Input	<p>Display data input from the LCD controller LSI.</p> <p>In case of the common driver mode or serial input mode, supply the input data to DI1 and DI2 ~ DI4 have to be set to V<sub>SS</sub> level or V<sub>DD</sub> level.</p>	Controller																										
DO	Output	DO is high level in the chip select mode	KS0083/84																										
NC		Non-Connection	NC																										

**MAXIMUM ABSOLUTE LIMIT**

Characteristic	Symbol	Value	Unit
Operating Voltage	$V_{DD}$	-7 ~ +0.3	V
Driver Supply Voltage	$V_{LCD}$	-30 ~ +0.3	
Input Voltage	$V_{IN}$	$V_{DD}-0.3 \sim +0.3$	
Operating Temperature	$T_{OPR}$	- 30 ~ + 85	°C
Storage Temperature	$T_{STG}$	- 55 ~ +150	

\* Voltage greater than above may damage to the circuit.

Maximum absolute limits are those values beyond which permanent damage to the device may occur. These are stress ratings only and functional operation of the device beyond them is not implied. Long exposure to these conditions may affect device reliability.

**ELECTRICAL CHARACTERISTICS**

**DC Characteristics** ( $V_{DD} = -5V \pm 10\%$ ,  $V_{SS} = 0V$ ,  $V_{EE} = -24V_i \pm V$ ,  $T_a = -30 \sim +85^\circ C$ )

Characteristic	Symbol	Condition	Min	Typ	Max	Unit	
Operating Current	$I_{DD}$	1 bit serial (3.3MHz)	-	-	5.0	mA	
		4 bit parallel (2.0MHz)	-	-	10.0	mA	
Input Voltage	High	$I_{IH}$	-	-	-	V	
	Low	$I_{IL}$	-	-	$0.8V_{DD}$	V	
Output Voltage	High	$I_{OH}$	$I_{OH} = -0.4mA$	-0.4	-	V	
	Low	$I_{OL}$	$I_{OL} = 0.4mA$	-	$V_{DD} + 0.4$	V	
Voltage	Descending (Vi-SCi)	$V_{D1}$	$I_{ON} = 1mA$ for one of SCi	-	-	1.0	V
		$V_{D2}$	$I_{ON} = 0.08mA$ for each SCi	-	-	1.5	V
Leakage Current	Input	$I_{LKG}$	-	-	1.0	$\mu A$	
	Output	$I_{O(LKG)}$	-	-	10.0	$\mu A$	



ELECTRONICS

**AC Characteristics**(V<sub>DD</sub>=-5V±10%, V<sub>SS</sub>=0V, V<sub>EE</sub>=-24V±3V; Ta=-30 ~ +85°C)

(1) Segment driver1; 1 bit serial data input (PS=Low, FCS=Low)

(refer to: Fig. 3)

Characteristic	Symbol	condition	Min	Max	Unit
Clock Cycle Time	t <sub>CY</sub>	-	300	-	ns
Clock Pulse Width	High Level	t <sub>WCKH</sub>	130	-	
	Low Level	t <sub>WCKL</sub>	130	-	
Set Up Time D Before CLK2; <sub>ε</sub>	t <sub>SU</sub>	-	70	-	
Hold Time D After CLK2; <sub>ε</sub>	t <sub>H</sub>	-	50	-	
Clock Margin Time 1 (From CLK1; <sub>ε</sub> To CLK2; <sub>ε</sub> )	t <sub>C1</sub>	-	20	-	
Clock Margin Time 2 (From CLK2; <sub>ε</sub> To CLK1; <sub>ε</sub> )	t <sub>C2</sub>	-	200	-	
Clock Margin Time 3 (From CLK2; <sub>ε</sub> To CLK1; <sub>ε</sub> )	t <sub>C3</sub>	-	20	-	
Clock Rise/Fall Time	t <sub>R</sub> , t <sub>F</sub>	-	-	50	
Output Delay Time	t <sub>D</sub>	C <sub>L</sub> =15pF	-	230	
High Level Latch Clock Width	t <sub>LWH</sub>	-	130	-	
Overlap Time Of CLK2 "L" And CLK1 "H"	t <sub>OV</sub>	-	130	-	

(2) segment driver; 4 bit data input (PS=High, FCS=Low)

(refer to: fig. 4)

Characteristic	Symbol	condition	Min	Max	Unit
Clock Cycle Time	t <sub>CY</sub>	-	500	-	ns
Clock Pulse Width	High Level	t <sub>WCKH</sub>	230	-	
	Low Level	t <sub>WCKL</sub>	230	-	
Set Up Time D Before CLK2 <sub>↓</sub>	t <sub>SU</sub>	-	70	-	
Hold Time D After CLK2 <sub>↓</sub>	t <sub>H</sub>	-	50	-	
Clock Margin Time 1 (From CLK1; <sub>ε</sub> To CLK2 <sub>↓</sub> )	t <sub>C1</sub>	-	20	-	
Clock Margin Time 2 (From CLK2; <sub>ε</sub> To CLK1 <sub>↓</sub> )	t <sub>C2</sub>	-	200	-	
Clock Margin Time 3 (From CLK2; <sub>ε</sub> To CLK1 <sub>↓</sub> )	t <sub>C3</sub>	-	20	-	
Clock Rise/Fall Time	t <sub>R</sub> , t <sub>F</sub>	-	-	50	
Output Delay Time	t <sub>D</sub>	C <sub>L</sub> =15pF	-	230	
High Level Latch Clock Width	t <sub>LWH</sub>	-	130	-	
Overlap Time Of CLK2 "L" And CLK1 "H"	t <sub>OV</sub>	-	130	-	

(3) Common Driver (PS=High, FCS=High)

(refer to: Fig. 5)

Characteristic	Symbol	condition	Min	Max	Unit
Clock Cycle Time	$t_{CY}$	-	1000	-	ns
Clock Pulse Width	High Level	$t_{WCKH}$	-	130	
	Low Level	$t_{WCKL}$	-	830	
Set-Up Time D before CLK↓	$t_{SU}$	-	70	-	
Hold Time D after CLK↓	$t_H$	-	50	-	
Output Delay Time	$t_D$	$C_L=15pF$	-	500	
Clock Rise/Fall Time	$t_R, t_F$	-	-	50	

(4) segment driver 2; 1 bit serial data input (PS=Low, FCS=High)

(refer to: Fig. 6)

Characteristic	Symbol	condition	Min	Max	Unit
Clock Cycle Time	$t_{CY}$	-	380	-	ns
Clock Pulse Width	High Level	$t_{WCKH}$	-	170	
	Low Level	$t_{WCKL}$	-	-	
Set Up Time D Before CLK↓	$t_{SU}$	-	70	-	
Hold Time D After CLK↓	$t_H$	-	50	-	
Clock Margin Time 1 (From CLK1↓To CLK2↓)	$t_{C1}$	-	20	-	
Clock Margin Time 2 (From CLK2↓To CLK1↓)	$t_{C2}$	-	200	-	
Clock Margin Time 3 (From CLK2↓To CLK1↓)	$t_{C3}$	-	20	-	
Clock Rise/Fall Time	$t_R, t_F$	-	-	50	
Output Delay Time	$t_D$	$C_L=15pF$	-	230	
High Level Latch Clock Width	$t_{WH}$	-	130	-	
Overlap Time Of CLK2 "L" And CLK1 "H"	$t_{OV}$	-	130	-	

NOTE : Input frequency, I/O reference level;  $0.8V_{DD}$ ,  $0.2V_{DD}$ 

1; Valid time (internal shift register)

2;  $(t_C \times 1.5) - (t_{C1}) - (t_{C3}) - (t_R \times 3)$ 

ELECTRONICS

TIMING CHARACTERISTICS



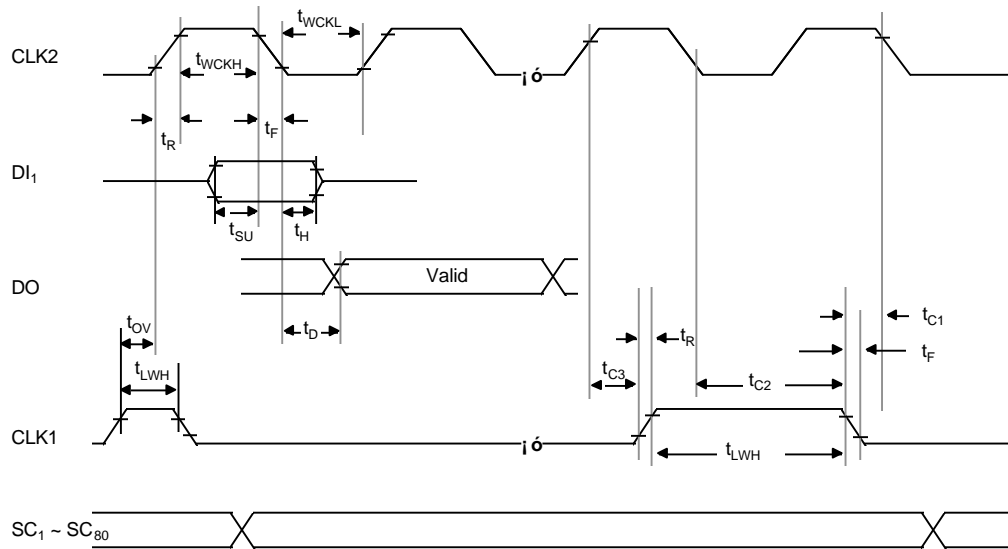

Fig. 3 Segment driver (1 bit serial input)

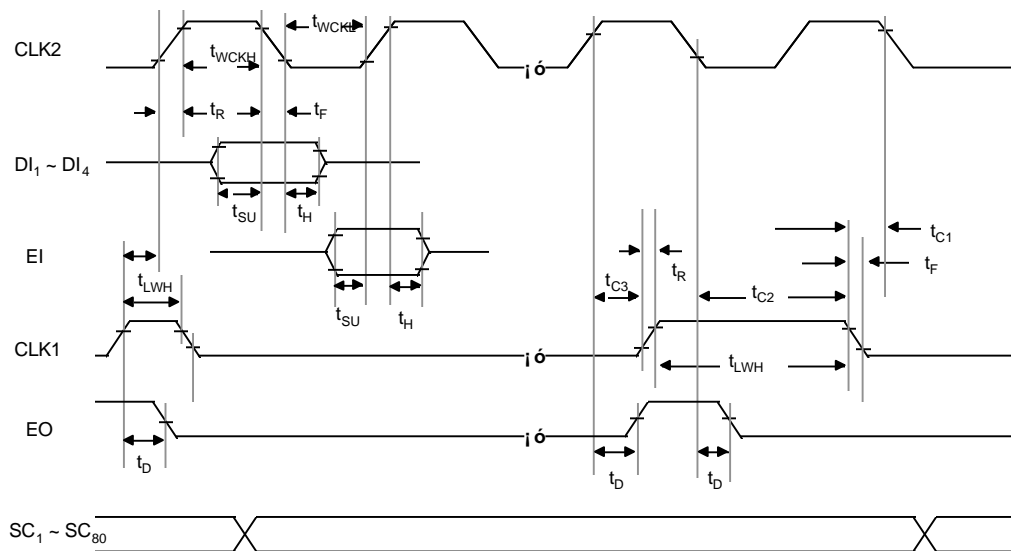

Fig. 4. 4-bit input segment driver  
 Fig. 4. Segment driver (4 bit input)

TIMING CHARACTERISTICS(continued)

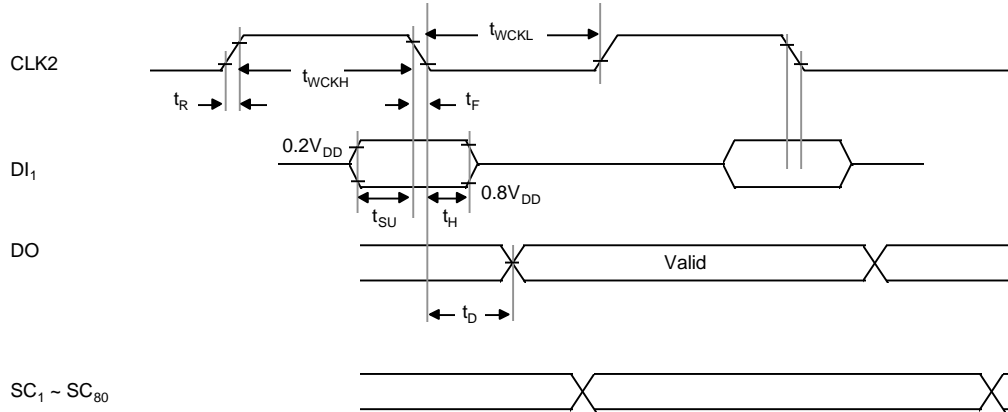

Fig. 5. Common driver

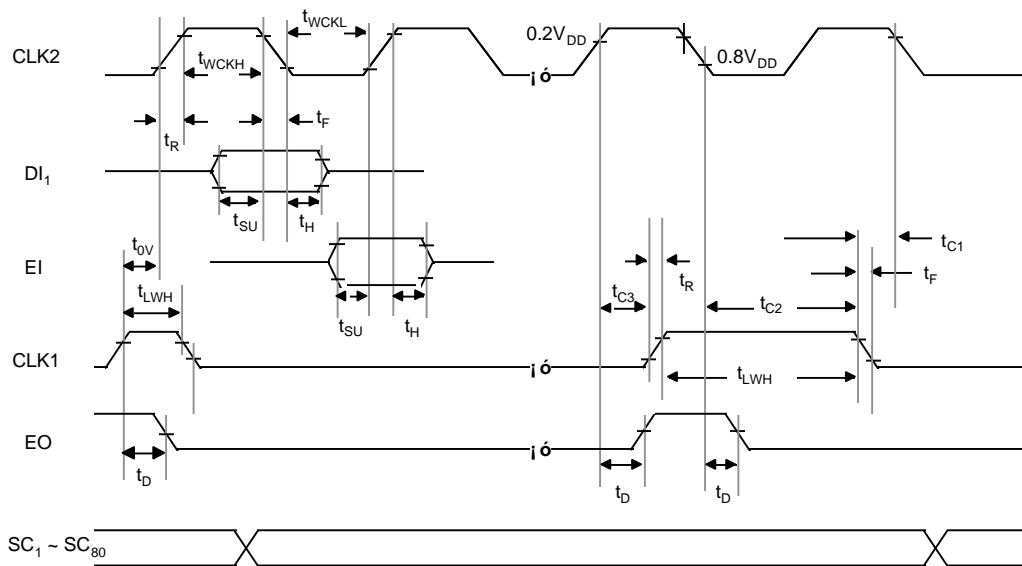
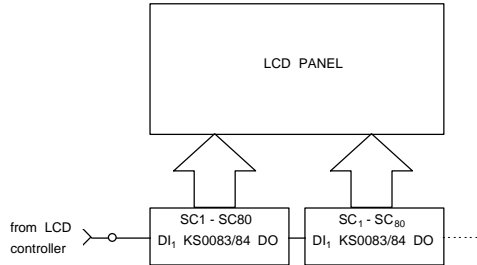

Fig. 6. Segment driver ( 1 bit serial data input )

**APPLICATION CIRCUIT**

**Mode Select**

1. segment driver 1;1 bit serial data input (FCS=L, PS=L)



2. segment driver;4 bit serial data input (FCS=L, PS=H)

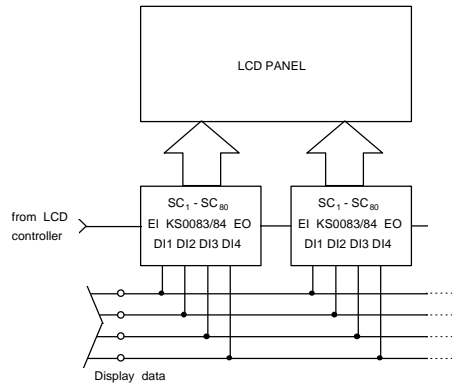

3. segment driver 2;1 bit serial data input (FCS=H, PS=L)

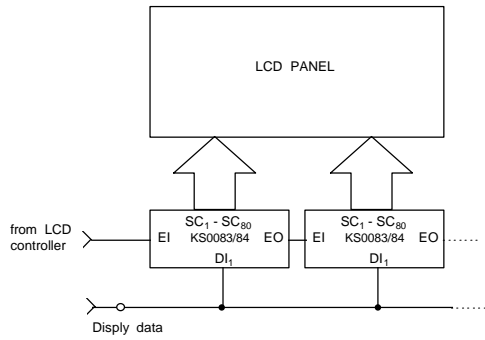

4. common driver (FCS=H, PS=H)

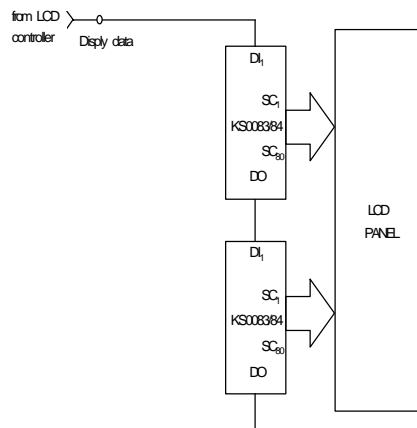

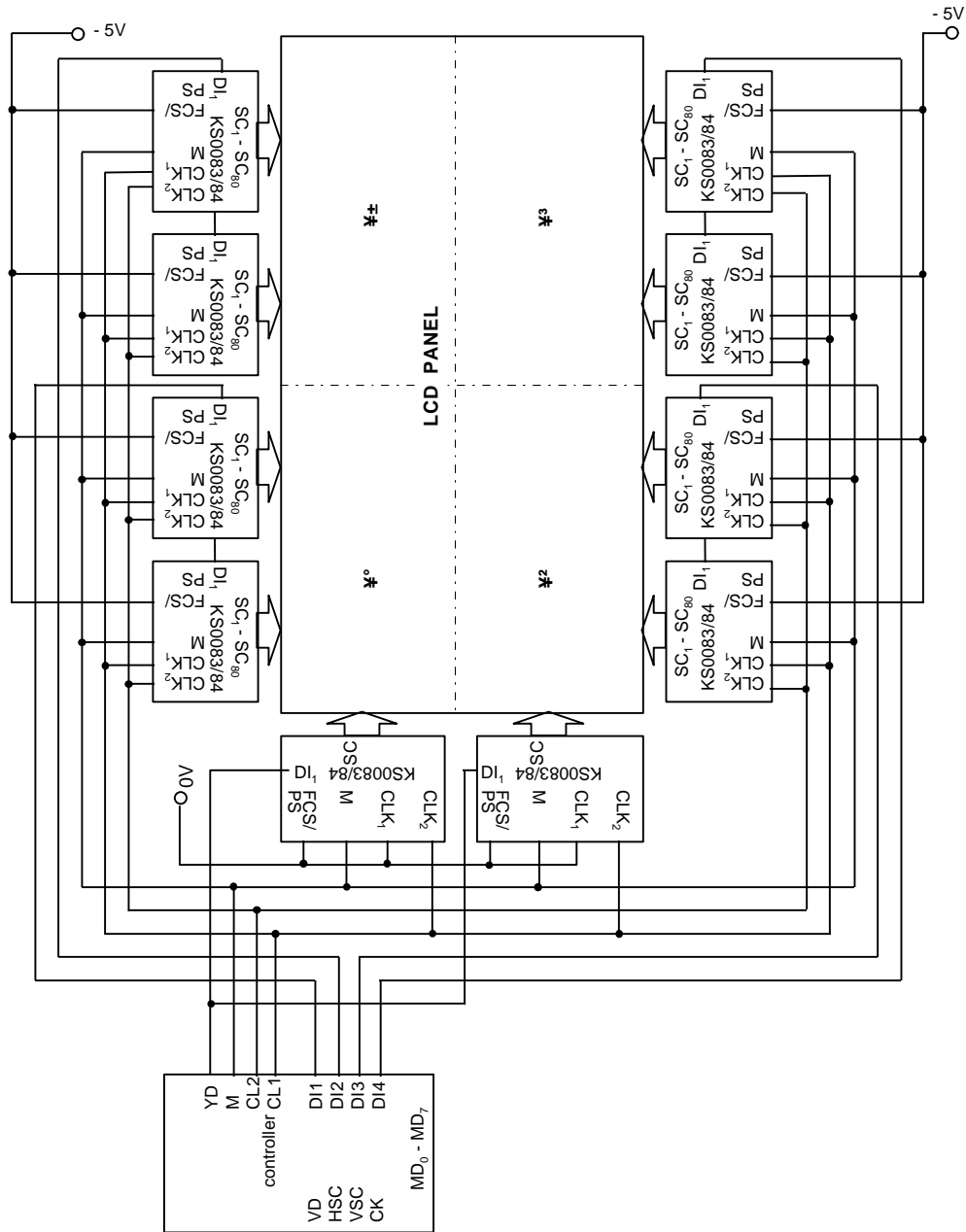

APPLICATION CIRCUIT

PAD DIAGRAM

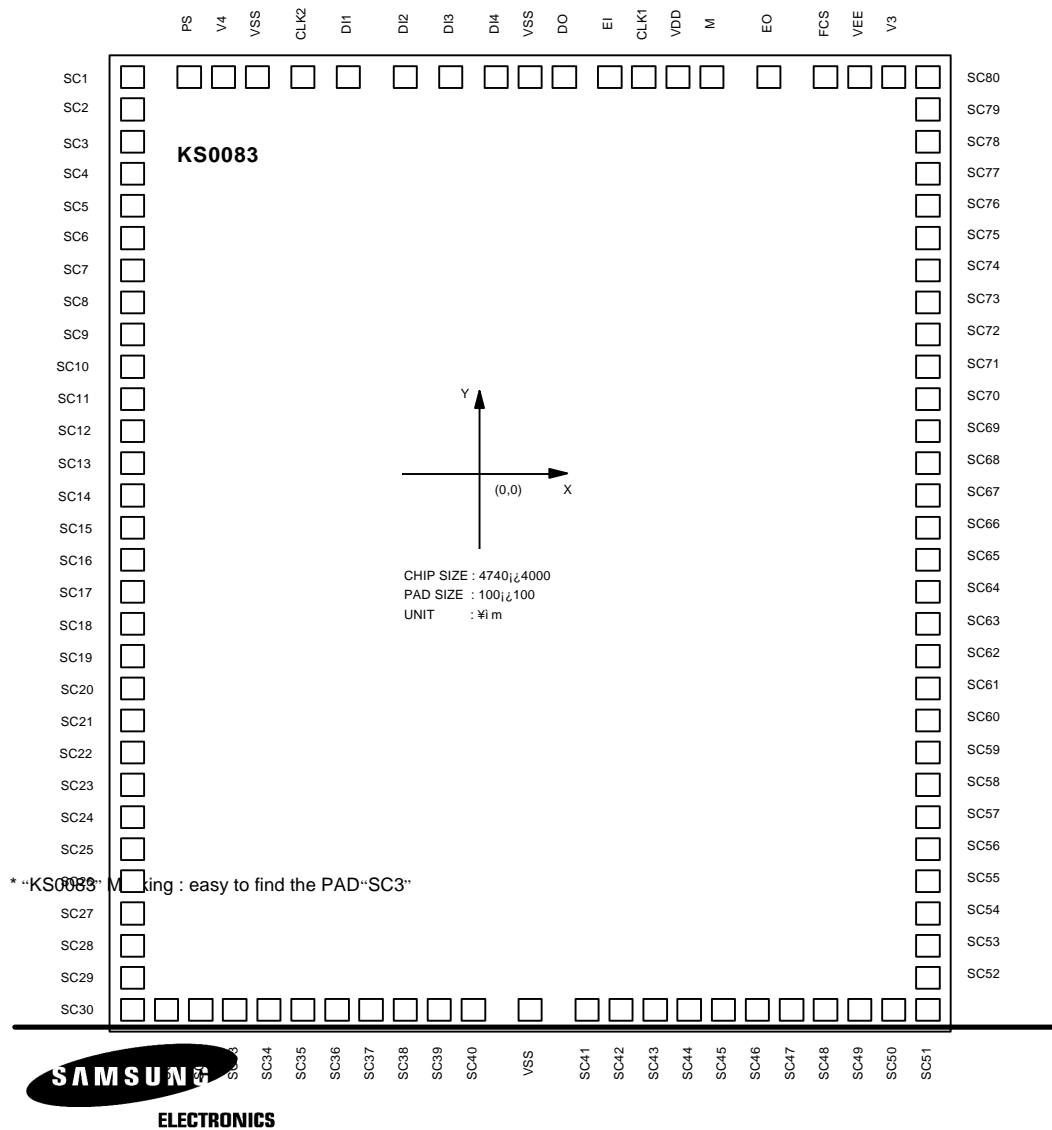

## PAD LOCATION

PAD NUMBER	PAD NAME	COORDINATE		PAD NUMBER	PAD NAME	COORDINATE		PAD NUMBER	PAD NAME	COORDINATE	
		X	Y			X	Y			X	Y
1	SC2	-1880	2095	35	SC36	-950	-2250	69	SC69	1880	540
2	SC3	-1880	1940	36	SC37	-795	-2250	70	SC70	1880	695
3	SC4	-1880	1785	37	SC38	-640	-2250	71	SC71	1880	850
4	SC5	-1880	1625	38	SC39	-485	-2250	72	SC72	1880	1005
5	SC6	-1880	1470	39	SC40	-330	-2250	73	SC73	1880	1160
6	SC7	-1880	1315	40	VSS	15	2250	74	SC74	1880	1315
7	SC8	-1880	1160	41	SC41	330	-2250	75	SC75	1880	1470
8	SC9	-1880	1005	42	SC42	485	-2250	76	SC76	1880	1625
9	SC10	-1880	850	43	SC43	640	-2250	77	SC77	1880	1785
10	SC11	-1880	695	44	SC44	795	-2250	78	SC78	1880	1940
11	SC12	-1880	540	45	SC45	950	-2250	79	SC79	1880	2095
12	SC13	-1880	385	46	SC46	1105	-2250	80	SC80	1880	2250
13	SC14	-1880	230	47	SC47	1260	-2250	81	V3	1725	2250
14	SC15	-1880	75	48	SC48	1415	-2250	82	VEE	1570	2250
15	SC16	-1880	-80	49	SC49	1570	-2250	83	FCS	1389	2250
16	SC17	-1880	-235	50	SC50	1725	-2250	84	EO	1140	2250
17	SC18	-1880	-390	51	SC51	1880	-2250	85	M	909	2250
18	SC19	-1880	-545	52	SC52	1880	-2095	86	VDD	718	2250
19	SC20	-1880	-700	53	SC53	1880	-1940	87	CLK1	527	2250
20	SC21	-1880	-855	54	SC54	1880	-1785	88	EI	337	2250
21	SC22	-1880	-1010	55	SC55	1880	-1630	89	DO	88	2250
22	SC23	-1880	-1165	56	SC56	1880	-1475	90	VSS	-111	2250
23	SC24	-1880	-1320	57	SC57	1880	-1320	91	DI4	-283	2250
24	SC25	-1880	-1475	58	SC58	1880	-1165	92	DI3	-511	2250
25	SC26	-1880	-1630	59	SC59	1880	-1010	93	DI2	-701	2250
26	SC27	-1880	-1785	60	SC60	1880	-855	94	DI1	920	2250
27	SC28	-1880	-1940	61	SC61	1880	-700	96	CLK2	-1119	2250
28	SC29	-1880	-2095	62	SC62	1880	-545	97	VSS	-1319	2250
29	SC30	-1880	-2250	63	SC63	1880	-390	98	V4	-1474	2250
30	SC31	-1725	-2250	64	SC64	1880	-235	99	PS	-1655	2250
31	SC32	-1570	-2250	65	SC65	1880	-80	100	SC1	-1880	2250
32	SC33	-1415	-2250	66	SC66	1880	75				
33	SC34	-1260	-2250	67	SC67	1880	230				
34	SC35	-1105	-2250	68	SC68	1880	385				

PAD DIAGRAM

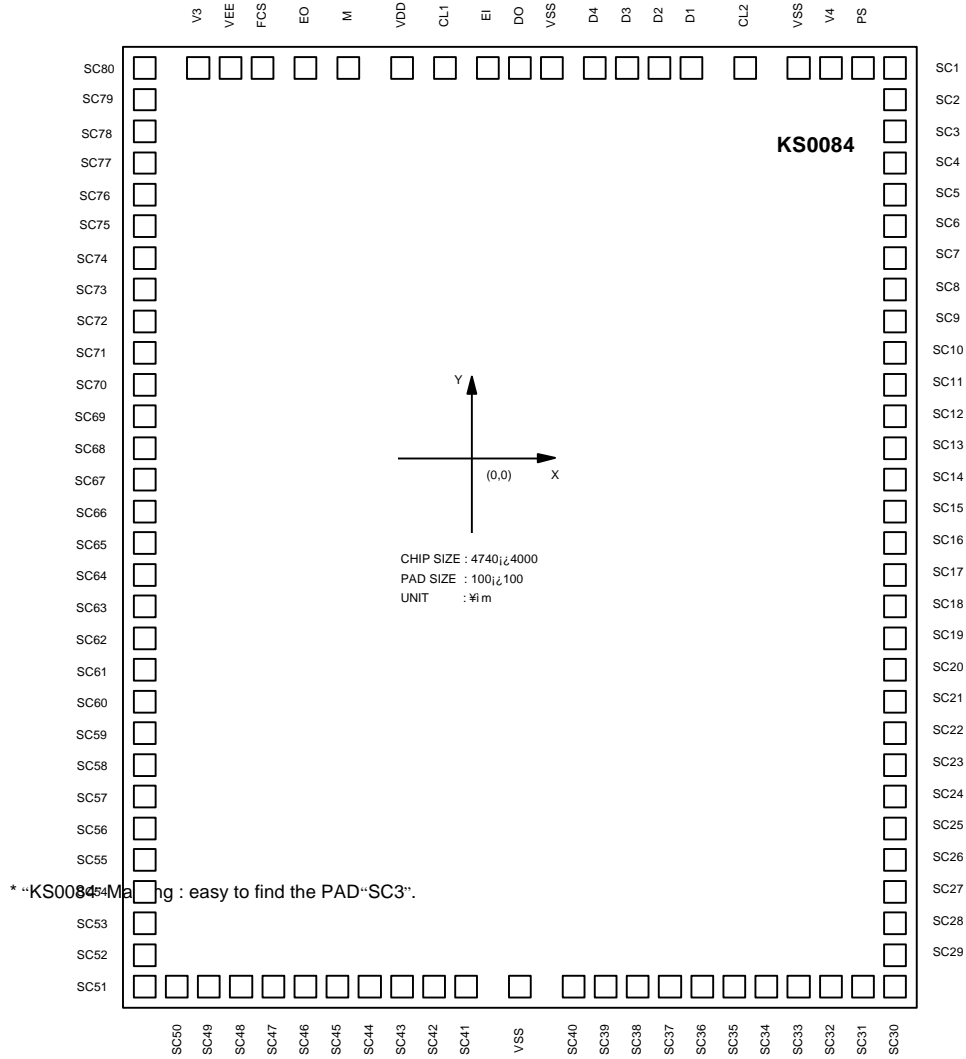

## PAD LOCATION

PAD NUMBER	PAD NAME	COORDINATE		PAD NUMBER	PAD NAME	COORDINATE		PAD NUMBER	PAD NAME	COORDINATE	
		X	Y			X	Y			X	Y
1	SC80	-1880	2250	SC46		35	-2250	69	SC13	1880	385
2	SC79	-1880	2095	SC45	-1105	36	-2250	70	SC12	1880	540
3	SC78	-1880	1940	SC44	-950	37	-2250	71	SC11	1880	695
4	SC77	-1880	1785	SC43	-795	38	-2250	72	SC10	1880	850
5	SC76	-1880	1625	SC42	-640	39	-2250	73	SC9	1880	1005
6	SC75	-1880	1470	SC41	-485	40	-2250	74	SC8	1880	1160
7	SC74	-1880	1315	VSS	-330	41	-2250	75	SC7	1880	1315
8	SC73	-1880	1160	SC40	-15	42	-2250	76	SC6	1880	1470
9	SC72	-1880	1005	SC39	330	43	-2250	77	SC5	1880	1625
10	SC71	-1880	850	SC38	485	44	-2250	78	SC4	1880	1785
11	SC70	-1880	695	SC37	640	45	-2250	79	SC3	1880	1940
12	SC69	-1880	540	SC36	795	46	-2250	80	SC2	1880	2095
13	SC68	-1880	385	SC35	950	47	-2250	81	SC1	1870	2250
14	SC67	-1880	230	SC34	1105	48	-2250	82	PS	1655	2250
15	SC66	-1880	75	SC33	1260	49	-2250	83	V4	1474	2250
16	SC65	-1880	-80	SC32	1415	50	-2250	84	VSS	1319	2250
17	SC64	-1880	-235	SC31	1570	51	-2250	85	CL2	1119	2250
18	SC63	-1880	-390	SC30	1725	52	-2250	87	D1	929	2250
19	SC62	-1880	-545	SC29	1880	53	-2095	88	D2	701	2250
20	SC61	-1880	-700	SC28	1880	54	-1940	89	D3	511	2250
21	SC60	-1880	-855	SC27	1880	55	-1785	90	D4	283	2250
22	SC59	-1880	-1010	SC26	1880	56	-1630	91	VSS	111	2250
23	SC58	-1880	-1165	SC25	1880	57	-1475	92	DO	-88	2250
24	SC57	-1880	-1320	SC24	1880	58	-1320	93	E1	-337	2250
25	SC56	-1880	-1475	SC23	1880	59	-1165	94	CL1	-527	2250
26	SC55	-1880	-1630	SC22	1880	60	-1010	95	VDD	-718	2250
27	SC54	-1880	-1785	SC21	1880	61	-855	96	M	-909	2250
28	SC53	-1880	-1940	SC20	1880	62	-700	97	EO	-1140	2250
29	SC52	-1880	-2095	SC19	1880	63	-545	98	FCS	-1389	2250
30	SC51	-1880	-2250	SC18	1880	64	-390	99	VEE	-1570	2250
31	SC50	-1725	-2250	SC17	1880	65	-235	100	V3	-1725	2250
32	SC49	-1570	-2250	SC16	1880	66	-80				
33	SC48	-1415	-2250	SC15	1880	67	75				
34	SC47	-1260	-2250	SC14	1880	68	230				
			-2250	SC67	1880		385				
				SC68	1880						